

The M14K™ core is a member of the MIPS32 *FamilyName* processor core family. It is fully configurable/synthesizable, especially well-suited for microcontrollers and embedded applications that have real-time requirements with a high level of performance efficiency and security requirements.

The M14K core implements the MIPS® Architecture in a 5-stage pipeline. It includes support for the microMIPS™ ISA, an Instruction Set Architecture with optimized MIPS32 16-bit and 32-bit instructions that provides a significant reduction in code size with a performance equivalent to MIPS32. The M14K core is an enhancement of the M4K®, designed from the same microarchitecture, including the Microcontroller Application-Specific Extension (MCU™ ASE), enhanced interrupt handling, lower interrupt latency, a memory protection unit (MPU), a reference design of an optimized interface for flash memory and built-in native AMBA®-3 AHB-Lite Bus Interface Unit (BIU), with additional power saving, debug, and profiling features.

Figure 1 shows a block diagram of the M14K core. The core is divided into *required* and *optional* (shown as shaded) blocks.

Figure 1 MIPS 32® M14K™ Core Block Diagram

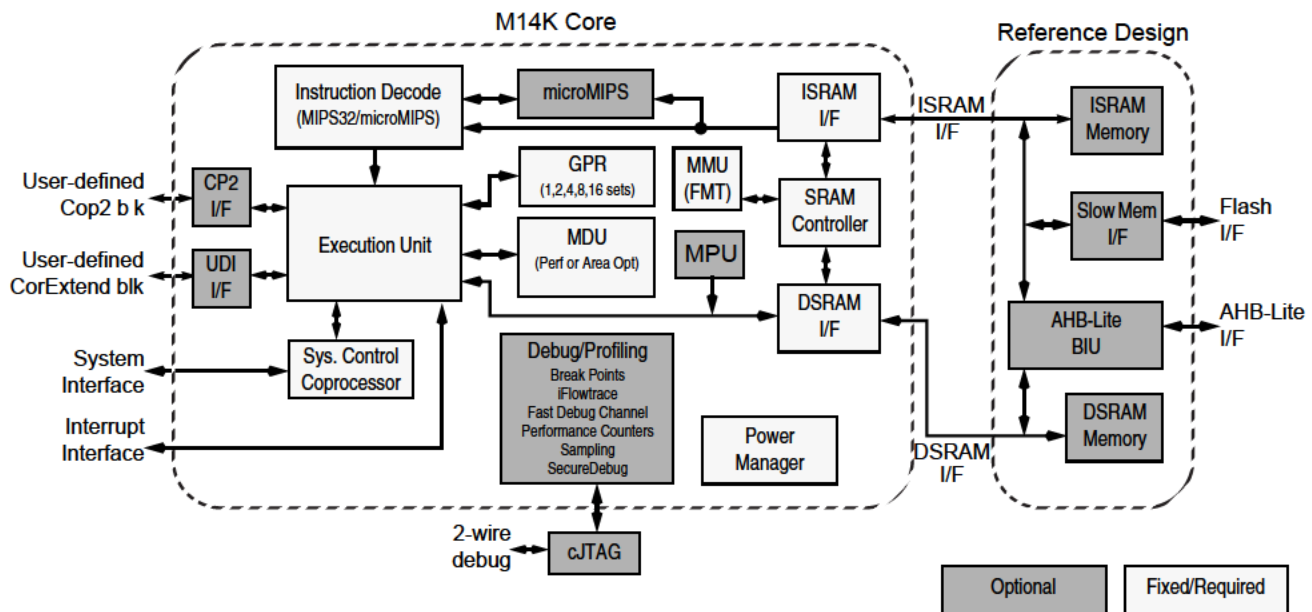

The M14K core retains the functionality from the M4K® processor core and adds some new features and functions. A summary of key features are:

- Support for MIPS32 Architecture.
- Support for microMIPS ISA to provide better code size compression with same MIPS32 performance.
- Support for multiple shadow register sets.
- The Memory Management Unit (MMU), consisting of a simple, Fixed Mapping Translation (FMT) mechanism.

- Multiply/Divide Unit (MDU) - the MDU can be configured for either performance or area optimizations. The high-performance optimization supports a single-cycle 32x16-bit MAC instruction or two-cycle 32x32-bit instructions.
- A simple SRAM-style interface that is configurable for independent instruction and data or as a unified interface. The SRAM interface enables deterministic response, while maintaining high-performance operation
- Support for the MCU ASE to enhance common functions used in microcontroller applications such as interrupts and semaphore manipulation.
- Security features such as the Memory Protection Unit to restrict execution capabilities from untrusted code and SecureDebug to restrict untrusted EJTAG debug access.
- Reference design for SRAM interface to AMBA-3 AHB-Lite bus and flash memory.
- Parity support.
- An optional Enhanced JTAG (EJTAG version 4.52) block allows for single-stepping of the processor as well as instruction and data virtual address/value breakpoints. iFlowtrace™ version 2.0 is also supported to add real-time instruction program counter and special events trace capability for debug. Additionally, Fast Debug Channel, Performance Counters, and PC/Data sampling functions are added to enrich debug and profiling features on the M14K core.
- External block to convert 4-wire EJTAG (IEEE 1149.1) interface to 2-wire cJTAG (IEEE 1149.7) interface.
- Configurable hardware breakpoints triggered by address match or address range.
- microMIPS ISA is a build-time configurable option that reduces code size over MIPS32, while maintaining MIPS32 performance.
- Combining both 16-bit and 32-bit opcodes, microMIPS supports all MIPS32 instructions (except branch-likely instructions) with new optimized encoding. Frequently used MIPS32 instructions are available as 16-bit instructions.
- Added fifteen new 32-bit instructions and thirty-nine 16-bit instructions.
- Stack pointer implicit in instruction.
- MIPS32 assembly and ABI-compatible.
- Supports MIPS architecture Modules and User-defined Instructions (UDIs).
- MCU™ ASE
 - Increases the number of interrupt hardware inputs from 6 to 8 for Vectored Interrupt (VI) mode, and from 63 to 255 for External Interrupt Controller (EIC) mode.
 - Separate priority and vector generation. 16-bit vector address is provided.
 - Hardware assist combined with the use of Shadow Register Sets to reduce interrupt latency during the prologue and epilogue of an interrupt.
 - An interrupt return with automated interrupt epilogue handling instruction (IRET) improves interrupt latency.
 - Supports optional interrupt chaining.
 - Two memory-to-memory atomic read-modify-write instructions (ASET and ACLR) eases commonly used semaphore manipulation in microcontroller applications. Interrupts are automatically disabled during the operation to maintain coherency.

Features

- 5-stage pipeline
- 32-bit Address and Data Paths
- MIPS32 Instruction Set Architecture
- MIPS32 Enhanced Architecture Features
 - Vectored interrupts and support for external interrupt controller
 - Programmable exception vector base
 - Atomic interrupt enable/disable
 - GPR shadow registers (one, three, seven, or fifteen additional shadows can be optionally added to minimize latency for interrupt handlers)
 - Bit field manipulation instructions
- microMIPS Instruction Set Architecture
 - Memory Management Unit
 - Simple Fixed Mapping Translation (FMT) mechanism
 - Memory Protection Unit
 - Optional feature that improves system security by restricting access, execution, and trace capabilities from untrusted code in predefined memory regions.
 - Simple SRAM-Style Interface
 - 32-bit address and data; input byte-enables enable simple connection to narrower devices
 - Single or multi-cycle latencies
 - Configuration option for dual or unified instruction/data interfaces
 - Redirection mechanism on dual I/D interfaces permits D-side references to be handled by I-side

- Transactions can be aborted
- Reference Design
 - A typical SRAM reference design is provided.
 - An AHB-Lite BIU reference design is provided between the SRAM interface and AHB-Lite Bus.
 - An optimized interface for slow memory (Flash) access using prefetch buffer scheme is provided.
- Parity Support
 - The ISRAM and DSRAM support optional parity detection.
- Multiply/Divide Unit (high-performance configuration)
 - Maximum issue rate of one 32x16 multiply per clock via on-chip 32x16 hardware multiplier array.
 - Maximum issue rate of one 32x32 multiply every other clock
 - Early-in iterative divide. Minimum 11 and maximum 34 clock latency (dividend (*rs*) sign extension-dependent)
- Multiply/Divide Unit (area-efficient configuration)
 - 32 clock latency on multiply
 - 34 clock latency on multiply-accumulate
 - 33-35 clock latency on divide (sign-dependent)
- CorExtend® User-Defined Instruction Set Extensions
 - Allows user to define and add instructions to the core at build time
 - Maintains full MIPS32 compatibility
 - Supported by industry-standard development tools
 - Single or multi-cycle instructions
- Multi-Core Support
 - External lock indication enables multi-processor semaphores based on LL/SC instructions
 - External sync indication allows memory ordering
 - Debug support includes cross-core triggers
- Coprocessor 2 interface
 - 32-bit interface to an external coprocessor
- Power Control
 - Minimum frequency: 0 MHz
 - Power-down mode (triggered by WAIT instruction)
 - Support for software-controlled clock divider
 - Support for extensive use of local gated clocks
- EJTAG Debug/Profiling and iFlowtrace™ Mechanism
 - CPU control with start, stop, and single stepping
 - Virtual instruction and data address/value breakpoints
- Hardware breakpoint supports both address match and address range triggering
- Optional simple hardware breakpoints on virtual addresses; 8I/4D, 6I/2D, 4I/2D, 2I/1D breakpoints, or no breakpoints
- Optional complex hardware breakpoints with 8I/4D, 6I/2D simple breakpoints
- TAP controller is chainable for multi-CPU debug
- Supports EJTAG (IEEE 1149.1) and compatible with cJTAG 2-wire (IEEE 1149.7) extension protocol
- Cross-CPU breakpoint support
- iFlowtrace support for real-time instruction PC and special events
- PC and/or load/store address sampling for profiling
- Performance Counters
- Support for Fast Debug Channel (FDC)
- SecureDebug
 - An optional feature that disables access via EJTAG in an untrusted environment
- Testability
 - Full scan design achieves test coverage in excess of 99% (dependent on library and configuration options)

Architecture Overview

The M14K core contains both required and optional blocks, as shown in [Figure 1](#). Required blocks must be implemented to remain MIPS-compliant. Optional blocks can be added to the M14K core based on the needs of the implementation.

The required blocks are as follows:

- Instruction Decode
- Execution Unit
- General Purposed Registers (GPR)
- Multiply/Divide Unit (MDU)
- System Control Coprocessor (CP0)
- Memory Management Unit (MMU)
- I/D SRAM Interfaces
- Power Management

Optional or configurable blocks include:

- Configurable instruction decoder supporting three ISA modes: MIPS32-only, MIPS32 and microMIPS, or microMIPS-only

- Memory Protection Unit (MPU)
- Reference Design of I/D-SRAM, BIU, Slow Memory Interface
- Coprocessor 2 interface
- CorExtend® User-Defined Instruction (UDI) interface
- Debug/Profiling with Enhanced JTAG (EJTAG) Controller, Break points, Sampling, Performance counters, Fast Debug Channel, and iFlowtrace logic

The section "MIPS32® M14K™ Core Required Logic Blocks" on page 5 discusses the required blocks. The section "MIPS32® M14K™ Core Optional or Configurable Logic Blocks" on page 10 discusses the optional blocks.

Pipeline Flow

The M14K core implements a 5-stage pipeline with a performance similar to the M4K® pipeline. The pipeline allows the processor to achieve high frequency while minimizing device complexity, reducing both cost and power consumption.

The M14K core pipeline consists of five stages:

- Instruction (I Stage)
- Execution (E Stage)
- Memory (M Stage)
- Align (A Stage)
- Writeback (W stage)

The M14K core implements a bypass mechanism that allows the result of an operation to be forwarded directly to the instruction that needs it without having to write the result to the register and then read it back.

Figure 2 shows a timing diagram of the M14K core pipeline (shown with the-high performance MDU).

Figure 2 MIPS32® M14K™ Core Pipeline

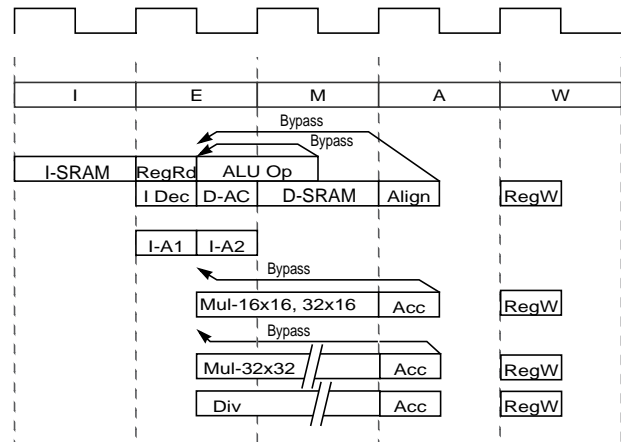

I Stage: Instruction Fetch

During the Instruction fetch stage:

- An instruction is fetched from the instructionSRAM.
- If both MIPS32 and microMIPS ISAs are supported, microMIPS instructions are converted to MIPS32-like instructions. If the MIPS32 ISA is not supported, 16-bit microMIPS instructions will be first recoded into 32-bit microMIPS equivalent instructions, and then decoded in native microMIPS ISA format.

E Stage: Execution

During the Execution stage:

- Operands are fetched from the register file.
- Operands from the M and A stage are bypassed to this stage.
- The Arithmetic Logic Unit (ALU) begins the arithmetic or logical operation for register-to-register instructions.
- The ALU calculates the virtual data address for load and store instructions, and the MMU performs the fixed virtual-to-physical address translation.
- The ALU determines whether the branch condition is true and calculates the virtual branch target address for branch instructions.
- Instruction logic selects an instruction address and the MMU performs the fixed virtual-to-physical address translation.
- All multiply and divide operations begin in this stage.

M Stage: Memory Fetch

During the Memory fetch stage:

- The arithmetic ALU operation completes.

- The data SRAM access is performed for load and store instructions.
- A 16x16 or 32x16 multiply calculation completes (high-performance MDU option).
- A 32x32 multiply operation stalls the MDU pipeline for one clock in the M stage (high-performance MDU option).
- A multiply operation stalls the MDU pipeline for 31 clocks in the M stage (area-efficient MDU option).
- A multiply-accumulate operation stalls the MDU pipeline for 33 clocks in the M stage (area-efficient MDU option).
- A divide operation stalls the MDU pipeline for a maximum of 34 clocks in the M stage. Early-in sign extension detection on the dividend will skip 7, 15, or 23 stall clocks (only the divider in the fast MDU option supports early-in detection).

A Stage: Align

During the Align stage:

- Load data is aligned to its word boundary.
- A multiply/divide operation updates the HI/LO registers (area-efficient MDU option).
- Multiply operation performs the carry-propagate-add. The actual register writeback is performed in the W stage (high-performance MDU option).
- A MUL operation makes the result available for writeback. The actual register writeback is performed in the W stage.
- EJTAG complex break conditions are evaluated.

W Stage: Writeback

During the Writeback stage:

- For register-to-register or load instructions, the instruction result is written back to the register file.

MIPS32® M14K™ Core Required Logic Blocks

The required logic blocks of the M14K core (Figure 1) are defined in the following subsections.

Execution Unit

The M14K core execution unit implements a load/store architecture with single-cycle ALU operations (logical, shift, add, subtract) and an autonomous multiply/divide unit.

The execution unit includes:

- Arithmetic Logic Unit (ALU) for performing arithmetic and bitwise logical operations. Shared adder for arithmetic operations, load/store address calculation, and branch target calculation.
- Address unit for calculating the next PC and next fetch address selection muxes.
- Load Aligner.
- Shifter and Store Aligner.
- Branch condition comparator.
- Trap condition comparator.
- Bypass muxes to advance result between two adjacent instructions with data dependency.
- Leading Zero/One detect unit for implementing the CLZ and CLO instructions.
- Actual execution of the Atomic Instructions defined in the MCU ASE.

General Purpose Registers

The M14K core contains thirty-two 32-bit general-purpose registers used for integer operations and address calculation. Optionally, one, three, seven or fifteen additional register file shadow sets (each containing thirty-two registers) can be added to minimize context switching overhead during interrupt/exception processing. The register file consists of two read ports and one write port and is fully bypassed to minimize operation latency in the pipeline.

Multiply/Divide Unit (MDU)

The M14K core includes a multiply/divide unit (MDU) that contains a separate, dedicated pipeline for integer multiply/divide operations. This pipeline operates in parallel with the integer unit (IU) pipeline and does not stall when the IU pipeline stalls. This allows the long-running MDU operations to be partially masked by system stalls and/or other integer unit instructions.

The MIPS architecture defines that the result of a multiply or divide operation be placed in a pair of *HI* and *LO* registers. Using the Move-From-HI (MFHI) and Move-From-LO (MFLO) instructions, these values can be transferred to the general-purpose register file.

There are two configuration options for the MDU: 1) a higher performance 32x16 multiplier block; 2) an area-efficient iterative multiplier block. . The selection of the MDU style allows the implementor to determine the appropriate performance and area trade-off for the application.

MDU with 32x16 High-Performance Multiplier

The high-performance MDU consists of a 32x16 Booth-recoded multiplier, a pair of result/accumulation registers (*HI* and *LO*), a divide state machine, and the necessary multiplexers and control logic. The first number shown ('32' of 32x16) represents the *rs* operand. The second number ('16' of 32x16) represents the *rt* operand. The M14K core only checks the value of the *rt* operand to determine how many times the operation must pass through the multiplier. The 16x16 and 32x16 operations pass through the multiplier once. A 32x32 operation passes through the multiplier twice.

The MDU supports execution of one 16x16 or 32x16 multiply or multiply-accumulate operation every clock cycle; 32x32 multiply operations can be issued every other clock cycle. Appropriate interlocks are implemented to stall the issuance of back-to-back 32x32 multiply operations. The multiply operand size is automatically determined by logic built into the MDU.

Table 1 and Table 2 list the repeat rate (how often the operation can be reissued when there is no data dependency) and latency (number of cycles until a result is available) for the multiply and divide instructions. The approximate latency and repeat rates are listed in terms of pipeline clocks. For a more detailed discussion of latencies and repeat rates, refer to Chapter 2 of the *MIPS32 M14K™ Processor Core Family Software User's Manual*.

Table 1 High-Performance Integer Multiply/Divide Unit Latencies and Repeat Rates

Opcode	Operand Size (mul <i>rt</i>) (div <i>rs</i>)	Latency	Repeat Rate
MUL (GPR destination)	16 bits	5	2
	32 bits	6	3
MULT, MULTU, MADD, MADDU, MSUB, MSUBU (Hi/Lo destination)	16 bits	2	1
	32 bits	3	2
DIV / DIVU (Hi/Lo destination)	8 bits	11-12 / 11	11-12 / 11
	16 bits	19-20 / 19	19-20 / 19
	24 bits	27-28 / 27	27-28 / 27
	32 bits	34-35 / 34	34-35 / 34

MDU with Area-Efficient Option

With the area-efficient option, multiply and divide operations are implemented with a simple 1-bit-per-clock iterative algorithm. Any attempt to issue a subsequent MDU instruction while a multiply/divide is still active causes an MDU pipeline stall until the operation is completed.

Table 2 lists the latency (number of cycles until a result is available) for the M14K core multiply and divide instructions. The latencies are listed in terms of pipeline clocks.

Table 2 Area-Efficient Integer Multiply/Divide Unit Operation Latencies

Opcode	Operand Size (mul <i>rt</i>) (div <i>rs</i>)	Latency	Repeat Rate
MUL (GPR destination)	any	35	32
MULT, MULTU, (Hi/Lo destination)	any	32	32
MADD, MADDU, MSUB, MSUBU (Hi/Lo destination)	any	34	34
DIV / DIVU (Hi/Lo destination)	any	33-34 / 33	33-34 / 33

Regardless of the multiplier array implementation, divide operations are implemented with a simple 1-bit-per-clock iterative algorithm. An early-in detection checks the sign extension of the dividend (*rs*) operand. If *rs* is 8 bits wide, 23 iterations are skipped. For a 16-bit-wide *rs*, 15 iterations are skipped, and for a 24-bit-wide *rs*, 7 iterations are skipped. Any attempt to issue a subsequent MDU instruction while a divide is still active causes an IU pipeline stall until the divide operation has completed.

System Control Coprocessor (CP0)

In the MIPS architecture, CP0 is responsible for the virtual-to-physical address translation, the exception control system, the processor's diagnostics capability, the operating modes (kernel, user, and debug), and whether interrupts are enabled or disabled. Configuration information, such as presence of build-time options like microMIPS, CorExtend Module or Coprocessor 2 interface, is also available by accessing the CP0 registers.

Coprocessor 0 also contains the logic for identifying and managing exceptions. Exceptions can be caused by a variety of sources, including boundary cases in data, external events, or program errors.

Interrupt Handling

The M14K core includes support for eight hardware interrupt pins, two software interrupts, and a timer interrupt. These interrupts can be used in any of three interrupt modes, as defined by Release 2 of the MIPS32 Architecture:

- Interrupt compatibility mode, which acts identically to that in an implementation of Release 1 of the Architecture.
- Vectored Interrupt (VI) mode, which adds the ability to prioritize and vector interrupts to a handler dedicated to that interrupt, and to assign a GPR shadow set for use during interrupt processing. The presence of this mode is denoted by the *VInt* bit in the *Config3* register. This mode is architecturally optional; but it is always present on the M14K core, so the *VInt* bit will always read as a 1 for the M14K core.
- External Interrupt Controller (EIC) mode, which redefines the way in which interrupts are handled to provide full support for an external interrupt controller handling prioritization and vectoring of interrupts. The presence of this mode denoted by the *VEIC* bit in the *Config3* register. Again, this mode is architecturally optional. On the M14K core, the *VEIC* bit is set externally by the static input, *SI_EICPresent*, to allow system logic to indicate the presence of an external interrupt controller.

The reset state of the processor is interrupt compatibility mode, such that a processor supporting Release 2 of the Architecture, the M14K core for example, is fully compatible with implementations of Release 1 of the Architecture.

VI or EIC interrupt modes can be combined with the optional shadow registers to specify which shadow set should be used on entry to a particular vector. The shadow registers further improve interrupt latency by avoiding the need to save context when invoking an interrupt handler.

In the M14K core, interrupt latency is reduced by:

- Speculative interrupt vector prefetching during the pipeline flush.
- Interrupt Automated Prologue (IAP) in hardware: Shadow Register Sets remove the need to save GPRs, and IAP removes the need to save specific Control Registers when handling an interrupt.

- Interrupt Automated Epilogue (IAE) in hardware: Shadow Register Sets remove the need to restore GPRs, and IAE removes the need to restore specific Control Registers when returning from an interrupt.
- Allow interrupt chaining. When servicing an interrupt and interrupt chaining is enabled, there is no need to return from the current Interrupt Service Routine (ISR) if there is another valid interrupt pending to be serviced. The control of the processor can jump directly from the current ISR to the next ISR without IAE and IAP.

GPR Shadow Registers

The MIPS32 Architecture optionally removes the need to save and restore GPRs on entry to high-priority interrupts or exceptions, and to provide specified processor modes with the same capability. This is done by introducing multiple copies of the GPRs, called *shadow sets*, and allowing privileged software to associate a shadow set with entry to kernel mode via an interrupt vector or exception. The normal GPRs are logically considered shadow set zero.

The number of GPR shadow sets is a build-time option. The M14K core allows 1 (the normal GPRs), 2, 4, 8, or 16 shadow sets. The highest number actually implemented is indicated by the *SRSCtl_{HSS}* field. If this field is zero, only the normal GPRs are implemented.

Shadow sets are new copies of the GPRs that can be substituted for the normal GPRs on entry to kernel mode via an interrupt or exception. Once a shadow set is bound to a kernel-mode entry condition, references to GPRs operate exactly as one would expect, but they are redirected to registers that are dedicated to that condition. Privileged software may need to reference all GPRs in the register file, even specific shadow registers that are not visible in the current mode, and the *RDPGPR* and *WRPGPR* instructions are used for this purpose. The *CSS* field of the *SRSCtl* register provides the number of the current shadow register set, and the *PSS* field of the *SRSCtl* register provides the number of the previous shadow register set that was current before the last exception or interrupt occurred.

If the processor is operating in VI interrupt mode, binding of a vectored interrupt to a shadow set is done by writing to the *SRSM_{ap}* register. If the processor is operating in EIC interrupt mode, the binding of the interrupt to a specific shadow set is provided by the external interrupt controller and is configured in an implementation-dependent way. Binding of an exception or non-vectored interrupt to a shadow set is done by writing to the *ESS* field of the *SRSCtl* register. When an exception or interrupt occurs, the value of *SRSCtl_{CSS}* is copied to *SRSCtl_{PSS}*, and *SRSCtl_{CSS}* is set to the value taken from the appropriate source. On an *ERET*, the value of *SRSCtl_{PSS}* is

copied back into $SRSCtl_{CSS}$ to restore the shadow set of the mode to which control returns.

Modes of Operation

The M14K core implements three modes of operation:

- *User mode* is most often used for applications programs.
- *Kernel mode* is typically used for handling exceptions and operating-system kernel functions, including CPO management and I/O device accesses.
- *Debug mode* is used during system bring-up and software development. Refer to the EJTAG section for more information on debug mode.

Figure 3 shows the virtual address map of the MIPS Architecture.

Figure 3 M14K™ Core Virtual Address Map

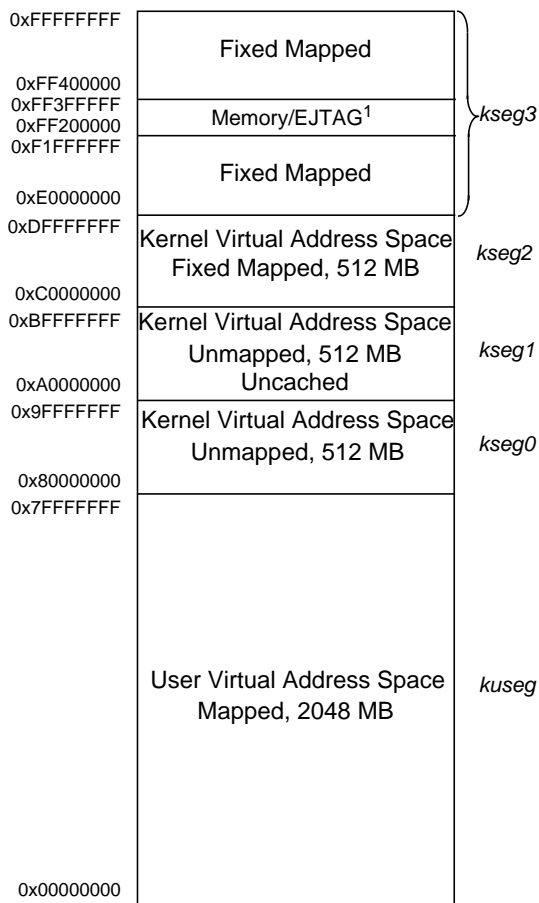

1. This space is mapped to memory in user or kernel mode, and by the EJTAG module in debug mode.

Memory Management Unit (MMU)

The M14K core contains a simple Fixed Mapping Translation (FMT) MMU that interfaces between the execution unit and the SRAM controller.

Fixed Mapping Translation (FMT)

A FMT is smaller and simpler than the full Translation Lookaside Buffer (TLB) style MMU found in other MIPS cores. Like a TLB, the FMT performs virtual-to-physical address translation and provides attributes for the different segments. Those segments that are unmapped in a TLB implementation (kseg0 and kseg1) are translated identically by the FMT.

Figure 4 shows how the FMT is implemented in the M14K core.

Figure 4 Address Translation During SRAM Access with FMT Implementation

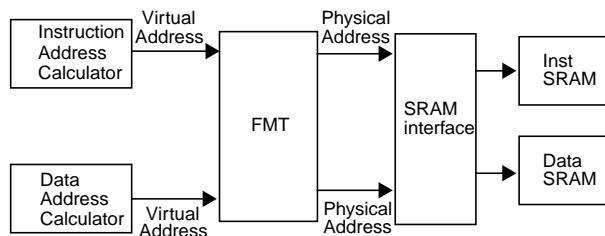

SRAM Interface Controller

Instead of caches, the M14K core contains an interface to SRAM-style memories that can be tightly coupled to the core. This permits deterministic response time with less area than is typically required for caches. The SRAM interface includes separate uni-directional 32-bit buses for address, read data, and write data.

Dual or Unified Interfaces

The SRAM interface includes a build-time option to select either dual or unified instruction and data interfaces.

The dual interface enables independent connection to instruction and data devices. It generally yields the highest performance, because the pipeline can generate simultaneous I and D requests, which are then serviced in parallel.

For simpler or cost-sensitive systems, it is also possible to combine the I and D interfaces into a common interface that services both types of requests. If I and D requests occur simultaneously, priority is given to the D side.

Back-stalling

Typically, read and write transactions will complete in a single cycle. However, if multi-cycle latency is desired, the interface can be stalled to allow connection to slower devices.

Redirection

When the dual I/D interface is present, a mechanism exists to divert D-side references to the I-side, if desired. The mechanism can be explicitly invoked for any other D-side references, as well. When the *DS_Redir* signal is asserted, a D-side request is diverted to the I-side interface in the following cycle, and the D-side will be stalled until the transaction is completed.

Transaction Abort

The core may request a transaction (fetch/load/store/sync) to be aborted. This is particularly useful in case of interrupts. Because the core does not know whether transactions are restartable, it cannot arbitrarily interrupt a request which has been initiated on the SRAM interface. However, cycles spent waiting for a multi-cycle transaction to complete can directly impact interrupt latency. In order to minimize this effect, the interface supports an abort mechanism. The core requests an abort whenever an interrupt is detected and a transaction is pending (abort of an instruction fetch may also be requested in other cases). The external system logic can choose to acknowledge or to ignore the abort request.

Connecting to Narrower Devices

The instruction and data read buses are always 32 bits in width. To facilitate connection to narrower memories, the SRAM interface protocol includes input byte-enables that can be used by system logic to signal validity as partial read data becomes available. The input byte-enables conditionally register the incoming read data bytes within the core, and thus eliminate the need for external registers to gather the entire 32 bits of data. External muxes are required to redirect the narrower data to the appropriate byte lanes.

Lock Mechanism

The SRAM interface includes a protocol to identify a locked sequence, and is used in conjunction with the LL/SC atomic read-modify-write semaphore instructions.

Sync Mechanism

The interface includes a protocol that externalizes the execution of the SYNC instruction. External logic might choose to use this information to enforce memory ordering between various elements in the system.

External Call Indication

The instruction fetch interface contains signals that indicate that the core is fetching the target of a subroutine call-type instruction such as JAL or BAL. At some point after a call, there will typically be a return to the original code sequence. If a system prefetches instructions, it can make use of this information to save instructions that were prefetched and are likely to be executed after the return.

Hardware Reset

The M14K core has two types of reset input signals: *SI_Reset* and *SI_ColdReset*. Functionally, these two signals are ORed together within the core and then used to initialize critical hardware state.

Both reset signals can be asserted either synchronously or asynchronously to the core clock, *SI_ClkIn*, and will trigger a Reset exception. The reset signals are active high and must be asserted for a minimum of 5 *SI_ClkIn* cycles. The falling edge triggers the Reset exception.

The primary difference between the two reset signals is that *SI_Reset* sets a bit in the *Status* register; this bit could be used by software to distinguish between the two reset signals, if desired. The reset behavior is summarized in [Table 3](#).

Table 3 Reset Types

SI_Reset	SI_ColdReset	Action
0	0	Normal operation, no reset.
1	0	Reset exception; sets <i>Status_{SR}</i> bit.
X	1	Reset exception.

One (or both) of the reset signals must be asserted at power-on or whenever hardware initialization of the core is desired. A power-on reset typically occurs when the machine is first turned on. A hard reset usually occurs when the machine is already on and the system is rebooted.

In debug mode, EJTAG can request that a soft reset (via the *SI_Reset* pin) be masked. It is system-dependent whether this functionality is supported. In normal mode, the *SI_Reset* pin cannot be masked. The *SI_ColdReset* pin is never masked.

Power Management

The M14K core offers a number of power management features, including low-power design, active power management, and power-down modes of operation. The core

is a static design that supports slowing or halting the clocks, which reduces system power consumption during idle periods.

The M14K core provides two mechanisms for system-level low-power support:

- Register-controlled power management
- Instruction-controlled power management

Register-Controlled Power Management

The *RP* bit in the CP0 *Status* register provides a software mechanism for placing the system into a low-power state. The state of the *RP* bit is available externally via the *SI_RP* signal. The external agent then decides whether to place the device in a low-power mode, such as reducing the system clock frequency.

Three additional bits, *Status_EXL*, *Status_ERL*, and *Debug_DM* support the power management function by allowing the user to change the power state if an exception or error occurs while the M14K core is in a low-power state. Depending on what type of exception is taken, one of these three bits will be asserted and reflected on the *SI_EXL*, *SI_ERL*, or *EJ_DebugM* outputs. The external agent can look at these signals and determine whether to leave the low-power state to service the exception.

The following four power-down signals are part of the system interface and change state as the corresponding bits in the CP0 registers are set or cleared:

- The *SI_RP* signal represents the state of the *RP* bit (27) in the CP0 *Status* register.
- The *SI_EXL* signal represents the state of the *EXL* bit (1) in the CP0 *Status* register.
- The *SI_ERL* signal represents the state of the *ERL* bit (2) in the CP0 *Status* register.
- The *EJ_DebugM* signal represents the state of the *DM* bit (30) in the CP0 *Debug* register.

Instruction-Controlled Power Management

The second mechanism for invoking power-down mode is by executing the WAIT instruction. When the WAIT instruction is executed, the internal clock is suspended; however, the internal timer and some of the input pins (*SI_Int[5:0]*, *SI_NMI*,

SI_Reset, and *SI_ColdReset*) continue to run. Once the CPU is in instruction-controlled power management mode, any interrupt, NMI, or reset condition causes the CPU to exit this mode and resume normal operation.

The M14K core asserts the *SI_Sleep* signal, which is part of the system interface bus, whenever the WAIT instruction is executed. The assertion of *SI_Sleep* indicates that the clock has stopped and the M14K core is waiting for an interrupt.

Local clock gating

The majority of the power consumed by the M14K core is in the clock tree and clocking registers. The core has support for extensive use of local gated-clocks. Power-conscious implementors can use these gated clocks to significantly reduce power consumption within the core.

MIPS32® M14K™ Core Optional or Configurable Logic Blocks

The M14K core contains several optional or configurable logic blocks, shown as shaded in the block diagram in [Figure 1](#).

Reference Design

The M14K core contains a reference design that shows a typical usage of the core with:

- Dual I-SRAM and D-SRAM interface with fast memories (i.e., SRAM) for instruction and data storage.
- Optimized interface for slow memory (i.e., Flash memory) access by having a prefetch buffer and a wider Data Read bus (i.e., IS_RData[127:0]) to speed up I-Fetch performance.
- AHB-lite bus interface to the system bus if the memory accesses are outside the memory map for the SRAM and Flash regions. AHB-Lite is a subset of the AHB bus protocol that supports a single bus master. The interface shares the same 32-bit Read and Write address bus and has two unidirectional 32-bit buses for Read and Write data.

The reference design is optional and can be modified by the user to better fit the SOC design requirement.

Figure 5 Reference Design Block Diagram.

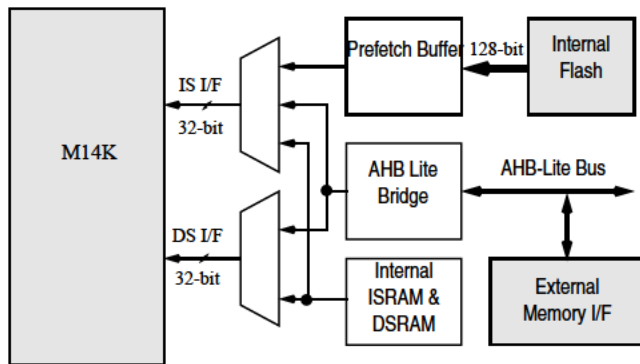

microMIPS™ ISA

The M14K core supports the microMIPS ISA, which contains all MIPS32 ISA instructions (except for branch-likely instructions) in a new 32-bit encoding scheme, with some of the commonly used instructions also available in 16-bit encoded format. This ISA improves code density through the additional 16-bit instructions while maintaining a performance similar to MIPS32 mode. In microMIPS mode, 16-bit or 32-bit instructions will be fetched and recoded to legacy MIPS32 instruction opcodes in the pipeline's I stage, so that the M14K core can have the same M4K® microarchitecture. Because the microMIPS instruction stream can be intermixed with 16-bit halfword or 32-bit word size instructions on halfword or word boundaries, additional logic is in place to address the word misalignment issues, thus minimizing performance loss.

Memory Protection Unit

The Memory Protection Unit can be configured to have from 1 to 16 memory protection regions. Each region is enabled by a set of Watch registers that define the address, size and protection of each memory region. The Memory Protection Unit control and Watch registers are implemented by CDMM (Common Device Memory Map) registers. After they have been programmed, these control registers can be locked to prohibit later modifications. Once programmed, a Protection Exception will be triggered when an Instruction Fetch or Data Access matches the address of the protected memory region or any modification of the EBase (base address of exception vectors) register was attempted. Each protected region can also disable the iFlowtrace capability. Typically, the Memory Protection Unit improves system security by disabling access to bootcode and preventing execution of non-trusted kernel mode code.

Coprocessor 2 Interface

The M14K core can be configured to have an interface for an on-chip coprocessor. This coprocessor can be tightly coupled to the processor core, allowing high-performance solutions integrating a graphics accelerator or DSP, for example.

The coprocessor interface is extensible and standardized on MIPS cores, allowing for design reuse. The M14K core supports a subset of the full coprocessor interface standard: 32b data transfer, no Coprocessor 1 support, single issue in-order data transfer to coprocessor, one out-of-order data transfer from coprocessor.

The coprocessor interface is designed to ease integration with customer IP. The interface allows high-performance communication between the core and coprocessor. There are no late or critical signals on the interface.

CorExtend® User-defined Instruction Extensions

An optional CorExtend User-defined Instruction (UDI) block enables the implementation of a small number of application-specific instructions that are tightly coupled to the core's execution unit. The interface to the UDI block is external to the M14K core.

Such instructions may operate on a general-purpose register, immediate data specified by the instruction word, or local state stored within the UDI block. The destination may be a general-purpose register or local UDI state. The operation may complete in one cycle or multiple cycles, if desired.

EJTAG Debug Support

The M14K core provides for an optional Enhanced JTAG (EJTAG) interface for use in the software debug of application and kernel code. In addition to standard user mode and kernel modes of operation, the M14K core provides a Debug mode that is entered after a debug exception (derived from a hardware breakpoint, single-step exception, etc.) is taken and continues until a debug exception return (DERET) instruction is executed. During this time, the processor executes the debug exception handler routine.

The EJTAG interface operates through the Test Access Port (TAP), a serial communication port used for transferring test data in and out of the M14K core. In addition to the standard JTAG instructions, special instructions defined in the EJTAG specification specify which registers are selected and how they are used.

Debug Registers

Four debug registers (*DEBUG*, *DEBUG2*, *DEPC*, and *DESAVE*) have been added to the MIPS Coprocessor 0 (CPO) register set. The *DEBUG* and *DEBUG2* registers show the cause of the debug exception and are used for setting up single-step operations. The *DEPC* (Debug Exception Program Counter) register holds the address on which the debug exception was taken, which is used to resume program execution after the debug operation finishes. Finally, the *DESAVE* (Debug Exception Save) register enables the saving of general-purpose registers used during execution of the debug exception handler.

To exit debug mode, a Debug Exception Return (DERET) instruction is executed. When this instruction is executed, the system exits debug mode, allowing normal execution of application and system code to resume.

EJTAG Hardware Breakpoints

There are several types of *simple* hardware breakpoints defined in the EJTAG specification. These stop the normal operation of the CPU and force the system into debug mode. There are two types of simple hardware breakpoints implemented in the M14K core: Instruction breakpoints and Data breakpoints. Additionally, *complex* hardware breakpoints can be included, which allow detection of more intricate sequences of events.

The M14K core can be configured with the following breakpoint options:

- No data or instruction, or complex breakpoints
- One data and two instruction breakpoints, without complex breakpoints
- Two data and four instruction breakpoints, without complex breakpoints
- Two data and six instruction breakpoints, with or without complex breakpoints
- Four data and eight instruction breakpoints, with or without complex breakpoints

Instruction breakpoints occur on instruction execution operations, and the breakpoint is set on the virtual address. A mask can be applied to the virtual address to set breakpoints on a binary range of instructions.

Data breakpoints occur on load/store transactions, and the breakpoint is set on a virtual address value, with the same single address or binary address range as the Instruction breakpoint. Data breakpoints can be set on a load, a store, or both. Data breakpoints can also be set to match on the operand value of the load/store operation, with byte-

granularity masking. Finally, masks can be applied to both the virtual address and the load/store value.

In addition, the M14K core has a configurable feature to support data and instruction address-range triggered breakpoints, where a breakpoint can occur when a virtual address is either within or outside a pair of 32-bit addresses. Unlike the traditional address-mask control, address-range triggering is not restricted to a power-of-two binary boundary.

Complex breakpoints utilize the simple instruction and data breakpoints and break when combinations of events are seen. Complex break features include:

- Pass Counters - Each time a matching condition is seen, a counter is decremented. The break or trigger will only be enabled when the counter has counted down to 0.
- Tuples - A tuple is the pairing of an instruction and a data breakpoint. The tuple will match if both the virtual address of the load or store instruction matches the instruction breakpoint, and the data breakpoint of the resulting load or store address and optional data value matches.
- Priming - This allows a breakpoint to be enabled only after other break conditions have been met. Also called sequential or armed triggering.
- Qualified - This feature uses a data breakpoint to qualify when an instruction breakpoint can be taken. Once a load matches the data address and the data value, the instruction break will be enabled. If a load matches the address, but has mis-matching data, the instruction break will be disabled.

Performance Counters

Performance counters are used to accumulate occurrences of internal predefined events/cycles/conditions for program analysis, debug, or profiling. A few examples of event types are clock cycles, instructions executed, specific instruction types executed, loads, stores, exceptions, and cycles while the CPU is stalled. There are two, 32-bit counters. Each can count one of the 64 internal predefined events selected by a corresponding control register. A counter overflow can be programmed to generate an interrupt, where the interrupt handler software can maintain larger total counts.

PC/Address Sampling

This sampling function is used for program profiling and hot-spots analysis. Instruction PC and/or Load/Store addresses can be sampled periodically. The result is scanned out through the EJTAG port. The Debug Control Register (*DCR*) is used to specify the sample period and the sample trigger.

Fast Debug Channel (FDC)

The M14K core includes optional FDC as a mechanism for high bandwidth data transfer between a debug host/probe and a target. FDC provides a FIFO buffering scheme to transfer data serially, with low CPU overhead and minimized waiting time. The data transfer occurs in the background, and the target CPU can either choose to check the status of the transfer periodically, or it can choose to be interrupted at the end of the transfer.

Figure 6 FDC Overview

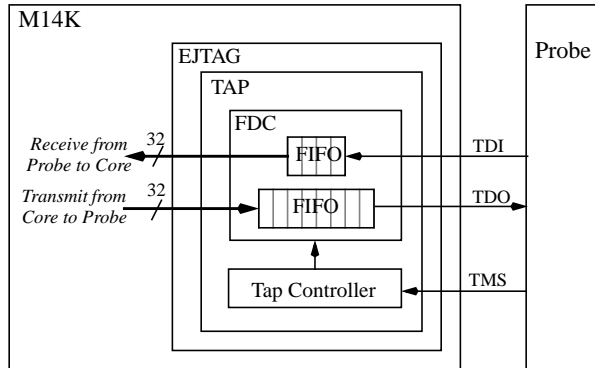

iFlowtrace™

The M14K core has an option for a simple trace mechanism called iFlowtrace. This mechanism only traces the instruction PC, not data addresses or values. This simplification allows the trace block to be smaller and the trace compression to be more efficient. iFlowtrace memory can be configured as off-chip, on-chip, or both.

iFlowtrace also offers special-event trace modes when normal tracing is disabled, namely:

- Function Call/Return and Exception Tracing mode to trace the PC value of function calls and returns and/or exceptions and returns.
- Breakpoint Match mode traces the breakpoint ID of a matching breakpoint and, for data breakpoints, the PC value of the instruction that caused it.
- Filtered Data Tracing mode traces the ID of a matching data breakpoint, the load or store data value, access type and memory access size, and the low-order address bits of the memory access, which is useful when the data breakpoint is set up to match a binary range of addresses.
- User Trace Messages. The user can instrument their code to add their own 32-bit value messages into the trace by writing to the Cop0 UTM register.

- Delta Cycle mode works in combination with the above trace modes to provide a timestamp between stored events. It reports the number of cycles that have elapsed since the last message was generated and put into the trace.

cJTAG Support

The M14K core provides an external conversion block which converts the existing EJTAG (IEEE 1149.1) 4-wire interface at the M14K core to a cJTAG (IEEE 1149.7) 2-wire interface. cJTAG reduces the number of wires from 4 to 2 and enables the support of Star-2 scan topology in the system debug environment.

Figure 7 cJTAG Support

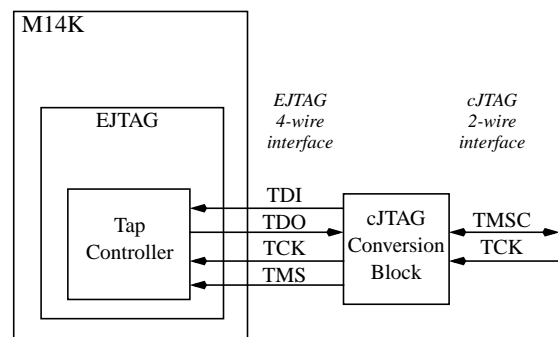

SecureDebug

SecureDebug improves security by disabling untrusted EJTAG debug access. An input signal is used to disable debug features, such as Probe Trap, Debug Interrupt Exception (EjtagBrk and DINT), EJTAGBOOT instruction, and PC Sampling.

Testability

Testability for production testing of the core is supported through the use of internal scan and memory BIST.

Internal Scan

Full mux-based scan for maximum test coverage is supported, with a configurable number of scan chains. ATPG test coverage can exceed 99%, depending on standard cell libraries and configuration options.

Memory BIST

Memory BIST for the on-chip trace memory is optional.

Memory BIST can be inserted with a CAD tool or other user-specified method. Wrapper modules and special side-band signal buses of configurable width are provided within the core to facilitate this approach.

Build-Time Configuration Options

The M14K core allows a number of features to be customized based on the intended application. Table 4 summarizes the

key configuration options that can be selected when the core is synthesized and implemented.

For a core that has already been built, software can determine the value of many of these options by checking an appropriate register field. Refer to the *MIPS32® M14K™ Processor Core Family Software User's Manual* for a more complete description of these fields. The value of some options that do not have a functional effect on the core are not visible to software.

Table 4 Build-time Configuration Options

Option	Choices	Software Visibility
Integer register file sets	1, 2, 4, 8 or 16	<i>SRSCtl</i> _{HSS}
Integer register file implementation style	Flops or generator	N/A
ISA support	MIPS32 only, or microMIPS only, or MIPS32 and microMIPS present	<i>Config</i> ³ _{ISA}
Multiply/divide implementation style	High performance or min area	<i>Config</i> _{MDU}
Memory Protection Unit	Present or not. If present 1 - 16 regions	N/A
Adder implementation style	Structured or Simple	N/A
EJTAG TAP controller	Present or not	N/A
EJTAG TAP Fast Debug Channel (FDC)	Present or not (even when TAP is present)	<i>DCR</i> _{FDCI}
EJTAG TAP FDC FIFO size	Two TX/two RX, or eight TX/four RX 32-bit registers	<i>FDCFG</i>
Instruction/data hardware breakpoints	0/0, 2/1, 4/2, 6/2, or 8/4	<i>DCR</i> _{InstBrk} , <i>IBS</i> _{BCN} <i>DCR</i> _{DataBrk} , <i>DBS</i> _{BCN}
Hardware breakpoint trigger by	Address match, or Address match and address range	<i>IBCn</i> _{hwart} , <i>DBCn</i> _{hwart}
Complex breakpoints	0/0, 6/2, or 8/4	<i>DCR</i> _{CBT}
Performance Counters	Present or not	<i>Config</i> _{1PC}
iFlowtrace hardware	Present or not	<i>Config</i> ³ _{ITL}
iFlowtrace memory location	On-core or off-chip	<i>IFCTL</i> _{ofc}
iFlowtrace on-chip memory size	256B - 8MB	N/A
CorExtend interface	Present or not	<i>Config</i> _{UDI} *
Coprocessor2 interface	Present or not	<i>Config</i> _{1C2} *
SRAM interface style	Separate instruction/data or unified	<i>Config</i> _{DS}
SRAM Parity	Present or not	<i>ErrCtl</i> _{PE}
* These bits indicate the presence of an external block. Bits will not be set if interface is present, but block is not.		

Table 4 Build-time Configuration Options (Continued)

Option	Choices	Software Visibility
Interrupt synchronizers	Present or not	N/A
Interrupt Vector Offset	Compute from Vector Input or Immediate Offset	N/A
Clock gating	Top-level, integer register file array, fine-grain, or none	N/A
PC Sampling	Present or not	Debug Control Register
Data Address Sampling	Present or not	Debug Control Register
PRID	User defined Processor Identification	PRID _{CompanyOpt}
* These bits indicate the presence of an external block. Bits will not be set if interface is present, but block is not.		

Revision History

Revision	Date	Description
01.00	November 2, 2009	• Initial 1_0_0 release.
02.00	December 17, 2010	• 2_0_0 Maintenance release.
02.01	September 30, 2011	• 2_1_0 Maintenance release.
02.02	March 12, 2012	• 2_1a_0 Patch release.
02.03	April 30, 2012	• 2_2_0 Maintenance release.
02.04	December 27, 2012	• 2_x_x Maintenance release.
02.05	March 24, 2014	• Changed document format and legal text.

Unpublished rights (if any) reserved under the copyright laws of the United States of America and other countries.

This document contains information that is proprietary to MIPS Tech, LLC, a Wave Computing company ("MIPS") and MIPS' affiliates as applicable. Any copying, reproducing, modifying or use of this information (in whole or in part) that is not expressly permitted in writing by MIPS or MIPS' affiliates as applicable or an authorized third party is strictly prohibited. At a minimum, this information is protected under unfair competition and copyright laws. Violations thereof may result in criminal penalties and fines. Any document provided in source format (i.e., in a modifiable form such as in FrameMaker or Microsoft Word format) is subject to use and distribution restrictions that are independent of and supplemental to any and all confidentiality restrictions. UNDER NO CIRCUMSTANCES MAY A DOCUMENT PROVIDED IN SOURCE FORMAT BE DISTRIBUTED TO A THIRD PARTY IN SOURCE FORMAT WITHOUT THE EXPRESS WRITTEN PERMISSION OF MIPS (AND MIPS' AFFILIATES AS APPLICABLE) reserve the right to change the information contained in this document to improve function, design or otherwise.

MIPS and MIPS' affiliates do not assume any liability arising out of the application or use of this information, or of any error or omission in such information. Any warranties, whether express, statutory, implied or otherwise, including but not limited to the implied warranties of merchantability or fitness for a particular purpose, are excluded. Except as expressly provided in any written license agreement from MIPS or an authorized third party, the furnishing of this document does not give recipient any license to any intellectual property rights, including any patent rights, that cover the information in this document.

The information contained in this document shall not be exported, reexported, transferred, or released, directly or indirectly, in violation of the law of any country or international law, regulation, treaty, Executive Order, statute, amendments or supplements thereto. Should a conflict arise regarding the export, reexport, transfer, or release of the information contained in this document, the laws of the United States of America shall be the governing law.

The information contained in this document constitutes one or more of the following: commercial computer software, commercial computer software documentation or other commercial items. If the user of this information, or any related documentation of any kind, including related technical data or manuals, is an agency, department, or other entity of the United States government ("Government"), the use, duplication, reproduction, release, modification, disclosure, or transfer of this information, or any related documentation of any kind, is restricted in accordance with Federal Acquisition Regulation 12.212 for civilian agencies and Defense Federal Acquisition Regulation Supplement 227.7202 for military agencies. The use of this information by the Government is further restricted in accordance with the terms of the license agreement(s) and/or applicable contract terms and conditions covering this information from MIPS Technologies or an authorized third party.

MIPS, MIPS I, MIPS II, MIPS III, MIPS IV, MIPS V, MIPSr3, MIPS32, MIPS64, microMIPS32, microMIPS64, MIPS-3D, MIPS16, MIPS16e, MIPS-Based, MIPSsim, MIPSpro, MIPS-VERIFIED, Aptiv logo, microAptiv logo, interAptiv logo, microMIPS logo, MIPS Technologies logo, MIPS-VERIFIED logo, proAptiv logo, 4K, 4Kc, 4Km, 4Kp, 4KE, 4KEc, 4KEm, 4KEp, 4KS, 4KSc, 4KSd, M4K, M14K, 5K, 5Kc, 5Kf, 24K, 24Kc, 24Kf, 24KE, 24KEc, 24KEf, 34K, 34Kc, 34Kf, 74K, 74Kc, 74Kf, 1004K, 1004Kc, 1004Kf, 1074K, 1074Kc, 1074Kf, R3000, R4000, R5000, Aptiv, ASMACRO, Atlas, "At the core of the user experience.", BusBridge, Bus Navigator, CLAM, CorExtend, CoreFPGA, CoreLV, EC, FPGA View, FS2, FS2 FIRST SILICON SOLUTIONS logo, FS2 NAVIGATOR, HyperDebug, HyperJTAG, IASim, iFlowtrace, interAptiv, JALGO, Logic Navigator, Malta, MDMX, MED, MGB, microAptiv, microMIPS, Navigator, OCl, PDtrace, the Pipeline, proAptiv, Pro Series, SEAD-3, SmartMIPS, SOC-it, and YAMON are trademarks or registered trademarks of MIPS and MIPS' affiliates as applicable in the United States and other countries.

All other trademarks referred to herein are the property of their respective owners.

U © U M h # 7) k U)