

The M5100 core is a member of the MIPS32® processor core family.

It is fully configurable/synthesizable, especially well-suited for microcontrollers and embedded applications that have real-time requirements with a high level of performance efficiency and security requirements.

The M5100 core implements the MIPS® Architecture Release-5 (“R5” incorporating enhanced functionality for next generation MIPS-Based™ products) in a 5-stage pipeline. It includes support for the microMIPS™ ISA, an Instruction Set Architecture with optimized MIPS32 16-bit and 32-bit instructions that provides a significant reduction in code size with a performance equivalent to MIPS32. The M5100 core is an enhancement of the microAptiv™ UC, designed from the same microarchitecture, including the Microcontroller Application-Specific Extension (MCU™ ASE), enhanced interrupt handling, lower interrupt latency, a reference design of an optimized interface for flash memory and built-in native AMBA®-3 AHB-Lite Bus Interface Unit (BIU), with additional power saving, security, debug, and profiling features. In addition, the M5100 core includes the MIPS Architecture Virtualization Module that enables virtualization of operating systems, which provides a scalable, trusted, and secure execution environment.

The M5100 core has an option to include the MIPS Architecture DSP Module Revision 2 that executes digital signal processing capabilities, with support for a number of powerful data processing operations. An optional IEEE 754 compliant Floating-Point Unit (FPU) provides both single and double precision instructions. Figure 1 shows a block diagram of the M5100 core. The core is divided into *required* and *optional* (shown as shaded) blocks.

Figure 1 MIPS 32® M5100 Core Block Diagram

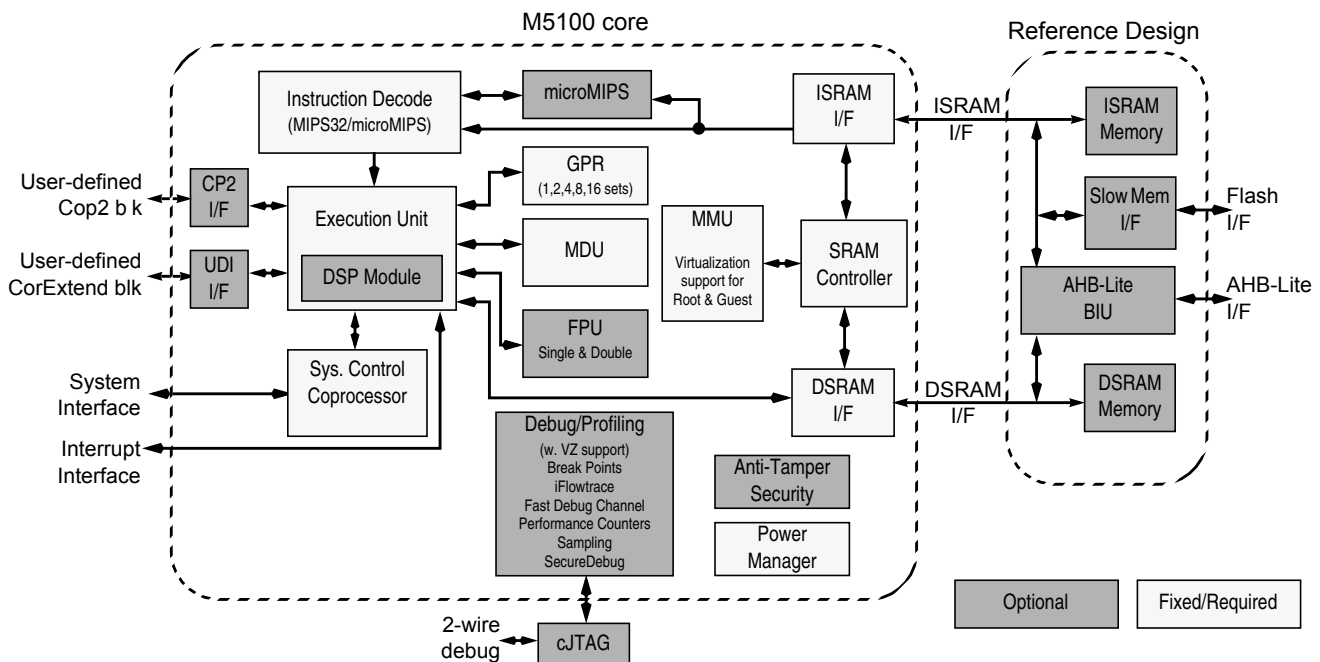

The M5100 core retains the functionality from the microAptiv™ UC processor core and adds some new features and functions. A summary of key features are:

- Support for MIPS32 Architecture Release-5.
- Support for microMIPS ISA to provide better code size compression with same MIPS32 performance.

- Support for multiple shadow register sets.
- The Memory Management Unit (MMU), consisting of a simple, Fixed Mapping Translation (FMT) mechanism.
- Supports configurable DSP Module Revision 2 for digital signal processing capabilities.
- Multiply/Divide Unit (MDU) - If the DSP is not included, the MDU can be configured for either performance or area optimizations. The high-performance optimization supports a single-cycle 32x16-bit MAC instruction or two-cycle 32x32-bit instructions. If the DSP is included, the MDU is enhanced with a hardware multiplier array supporting single-cycle 32x32 MAC and DSP instructions.
- Floating-Point Unit (FPU), an IEEE-754 compliant Floating-Point Unit with single and double precision datatypes.
- A simple SRAM-style interface that is configurable for independent instruction and data or as a unified interface. The SRAM interface enables deterministic response, while maintaining high-performance operation
- Support for the MCU ASE to enhance common functions used in microcontroller applications such as interrupts and semaphore manipulation.
- Security features such as the SecureDebug to restrict untrusted EJTAG debug access.
- Support for the Virtualization Module via privileged (root) and unprivileged (guest) operating modes. Legacy software will run in guest mode where all operations are monitored and trapped by hypervisor software if the guest does not behave as expected. The hypervisor operates invisibly to the guest, and enforces data protection between guests.
- Reference design for SRAM interface to AMBA-3 AHB-Lite bus and flash memory.
- Parity support.
- An optional Enhanced JTAG (EJTAG version 4.52) block allows for single-stepping of the processor as well as instruction and data virtual address/value breakpoints. iFlowtrace™ version 2.0 is also supported to add real-time instruction program counter and special events trace capability for debug. Additionally, Fast Debug Channel, Performance Counters, and PC/Data sampling functions are added to enrich debug and profiling features on the M5100 core.
- External block to convert 4-wire EJTAG (IEEE 1149.1) interface to 2-wire cJTAG (IEEE 1149.7) interface.
- Configurable hardware breakpoints triggered by address match or address range.

Features

- 5-stage pipeline
- 32-bit Address and Data Paths
- MIPS32 Instruction Set Architecture
- MIPS32 Enhanced Architecture Features
 - Vectored interrupts and support for external interrupt controller
 - Programmable exception vector base
 - Atomic interrupt enable/disable
 - GPR shadow registers (one, three, seven, or fifteen additional shadows can be optionally added to minimize latency for interrupt handlers)
 - Bit field manipulation instructions
- microMIPS Instruction Set Architecture
 - microMIPS ISA is a build-time configurable option that reduces code size over MIPS32, while maintaining MIPS32 performance.
 - Combining both 16-bit and 32-bit opcodes, microMIPS supports all MIPS32 instructions (except branch-likely instructions) with new optimized encoding. Frequently used MIPS32 instructions are available as 16-bit instructions.
 - Added fifteen new 32-bit instructions and thirty-nine 16-bit instructions.
 - Stack pointer implicit in instruction.
 - MIPS32 assembly and ABI-compatible.
 - Supports MIPS architecture Modules and User-defined Instructions (UDIs).
- MCU™ ASE
 - Increases the number of interrupt hardware inputs from 6 to 8 for Vectored Interrupt (VI) mode, and from 63 to 255 for External Interrupt Controller (EIC) mode.
 - Separate priority and vector generation. 16-bit vector address is provided.
 - Hardware assist combined with the use of Shadow Register Sets to reduce interrupt latency during the prologue and epilogue of an interrupt.
 - An interrupt return with automated interrupt epilogue handling instruction (IRET) improves interrupt latency.
 - Supports optional interrupt chaining.
 - Two memory-to-memory atomic read-modify-write instructions (ASET and ACLR) eases commonly used semaphore manipulation in microcontroller applications. Interrupts are automatically disabled during the operation to maintain coherency.

- Memory Management Unit
 - Simple Fixed Mapping Translation (FMT) mechanism
- Virtualization Module Support
 - Support for the Virtualization Module using “trap and emulate” techniques.
 - Two new operating modes: privileged (root) and unprivileged (guest)
 - System resources controlled through privileged instructions while executing in privileged mode
 - Execution of a privileged instruction in unprivileged mode will cause an exception (trap), returning control to privileged-mode software
 - Address translation is performed on the entire address space when in unprivileged mode
 - Configurable from 1 to 7 guests
 - Supports RPU (Root Protection Unit) memory management unit
- Simple SRAM-Style Interface
 - 32-bit address and data; input byte-enables enable simple connection to narrower devices
 - Single or multi-cycle latencies
 - Configuration option for dual or unified instruction/data interfaces
 - Redirection mechanism on dual I/D interfaces permits D-side references to be handled by I-side
 - Transactions can be aborted
- Reference Design
 - A typical SRAM reference design is provided.
 - An AHB-Lite BIU reference design is provided between the SRAM interface and AHB-Lite Bus.
 - An optimized interface for slow memory (Flash) access using prefetch buffer scheme is provided.
- Parity Support
 - The ISRAM and DSRAM support optional parity detection.
- MIPS DSP Module (Revision 2.0)
 - Support for MAC operations with 3 additional pairs of Hi/Lo accumulator registers (Ac0 - Ac3)
 - Fractional data types (Q15, Q31) with rounding support
 - Saturating arithmetic with overflow handling
 - SIMD instructions operate on 2x16-bit or 4x8-bit operands simultaneously
 - Separate MDU pipeline with full-sized hardware multiplier to support back-to-back operations
 - The DSP Module is build-time configurable.
- Multiply/Divide Unit (high-performance configuration without DSP)
 - Maximum issue rate of one 32x16 multiply per clock via on-chip 32x16 hardware multiplier array.
 - Maximum issue rate of one 32x32 multiply every other clock
 - Early-in iterative divide. Minimum 11 and maximum 34 clock latency (dividend (*rs*) sign extension-dependent)
- Multiply/Divide Unit (with DSP configuration)
 - Maximum issue rate of one 32x32 multiply per clock via on-chip 32x32 hardware multiplier array
 - Maximum issue rate of one 32x32 multiply every clock
 - Early-in iterative divide. Minimum 12 and maximum 38clock latency (dividend (*rs*) sign extension-dependent)
- Multiply/Divide Unit (area-efficient configuration without DSP)
 - 32 clock latency on multiply
 - 34 clock latency on multiply-accumulate
 - 33-35 clock latency on divide (sign-dependent)
- Floating Point Unit (FPU)
 - 1985 IEEE-754 compliant Floating Point Unit.
 - Supports single and double precision datatypes
 - 2008 IEEE-754 compatibility control for NaN handling and Abs/Neg instructions
 - Runs at 1:1 core/FPU clock ratio.
 - The FPU is build-time configurable.
- CorExtend® User-Defined Instruction Set Extensions
 - Allows user to define and add instructions to the core at build time
 - Maintains full MIPS32 compatibility
 - Supported by industry-standard development tools
 - Single or multi-cycle instructions
- Multi-Core Support
 - External lock indication enables multi-processor semaphores based on LL/SC instructions
 - External sync indication allows memory ordering
 - Debug support includes cross-core triggers
- Coprocessor 2 interface
 - 32-bit interface to an external coprocessor
- Anti-Tamper Security Features

- Injection of random pipeline slips controlled via CP0 register
- Fast general-purpose 32-bit pseudo random generator accessible via CP0 register
- Complex pseudo random generator for hardware use controlled via user-defined seed
- Power Control
 - Minimum frequency: 0 MHz
 - Power-down mode (triggered by WAIT instruction)
 - Support for software-controlled clock divider
 - Support for extensive use of local gated clocks
- EJTAG Debug/Profiling and iFlowtrace™ Mechanism
 - CPU control with start, stop, and single stepping
 - Virtual instruction and data address/value breakpoints
 - Hardware breakpoint supports both address match and address range triggering
 - Optional simple hardware breakpoints on virtual addresses; 8I/4D, 6I/2D, 4I/2D, 2I/1D breakpoints, or no breakpoints
 - Optional complex hardware breakpoints with 8I/4D, 6I/2D simple breakpoints
 - TAP controller is chainable for multi-CPU debug
 - Supports EJTAG (IEEE 1149.1) and compatible with cJTAG 2-wire (IEEE 1149.7) extension protocol
 - Cross-CPU breakpoint support
 - iFlowtrace support for real-time instruction PC and special events
 - PC and/or load/store address sampling for profiling
 - Performance Counters
 - Support for Fast Debug Channel (FDC)
- SecureDebug
 - An optional feature that disables access via EJTAG in an untrusted environment
- Testability
 - Full scan design achieves test coverage in excess of 99% (dependent on library and configuration options)

Architecture Overview

The M5100 core contains both required and optional blocks, as shown in [Figure 1](#). Required blocks must be implemented to remain MIPS-compliant. Optional blocks can be added to the M5100 core based on the needs of the implementation.

The required blocks are as follows:

- Instruction Decode
- Execution Unit
- General Purposed Registers (GPR)
- Multiply/Divide Unit (MDU)
- System Control Coprocessor (CP0)
- Memory Management Unit (MMU)
- I/D SRAM Interfaces
- Power Management

Optional or configurable blocks include:

- Configurable instruction decoder supporting three ISA modes: MIPS32-only, MIPS32 and microMIPS, or microMIPS-only
- DSP (integrated with MDU)
- Floating-point Unit (FPU)
- Virtualization support (integrated with MMU)
- Reference Design of I/D-SRAM, BIU, Slow Memory Interface
- Anti-Tamper Security Block
- Coprocessor 2 interface
- CorExtend® User-Defined Instruction (UDI) interface
- Debug/Profiling with Enhanced JTAG (EJTAG) Controller, Break points, Sampling, Performance counters, Fast Debug Channel, and iFlowtrace logic

The section "[MIPS32® M5100 Core Required Logic Blocks](#)" on page 6 discusses the required blocks. The section "[MIPS32® M5100 Core Optional or Configurable Logic Blocks](#)" on page 12 discusses the optional blocks.

Pipeline Flow

The M5100 core implements a 5-stage pipeline with a performance similar to the microAptiv™ UC pipeline. The pipeline allows the processor to achieve high frequency while minimizing device complexity, reducing both cost and power consumption.

The M5100 core pipeline consists of five stages:

- Instruction (I Stage)
- Execution (E Stage)
- Memory (M Stage)
- Align (A Stage)
- Writeback (W stage)

The M5100 core implements a bypass mechanism that allows the result of an operation to be forwarded directly to the instruction that needs it without having to write the result to the register and then read it back.

Figure 2 shows a timing diagram of the M5100 core pipeline (shown with the high performance MDU).

Figure 2 MIPS32® M5100 Core Pipeline

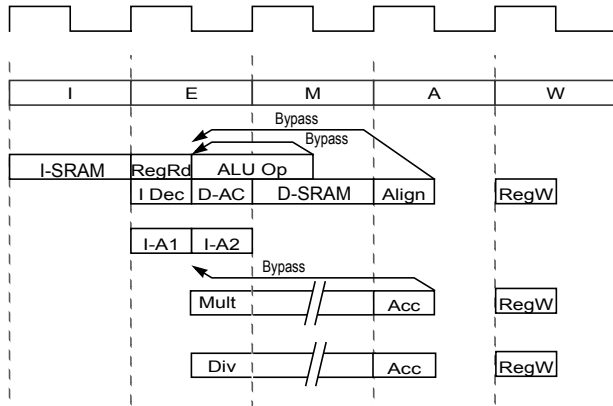

I Stage: Instruction Fetch

During the Instruction fetch stage:

- An instruction is fetched from the instructionSRAM.
- If both MIPS32 and microMIPS ISAs are supported, microMIPS instructions are converted to MIPS32-like instructions. If the MIPS32 ISA is not supported, 16-bit microMIPS instructions will be first recoded into 32-bit microMIPS equivalent instructions, and then decoded in native microMIPS ISA format.

E Stage: Execution

During the Execution stage:

- Operands are fetched from the register file.
- Operands from the M and A stage are bypassed to this stage.
- The Arithmetic Logic Unit (ALU) begins the arithmetic or logical operation for register-to-register instructions.
- The ALU calculates the virtual data address for load and store instructions, and the MMU performs the fixed virtual-to-physical address translation.
- The ALU determines whether the branch condition is true and calculates the virtual branch target address for branch instructions.
- Instruction logic selects an instruction address and the MMU performs the fixed virtual-to-physical address translation.

- All multiply and divide operations begin in this stage.

M Stage: Memory Fetch

During the Memory fetch stage:

- The arithmetic ALU operation completes.
- The data SRAM access is performed for load and store instructions.
- A 32x32 multiply calculation completes (with DSP configuration).
- A 32x32 multiply operation stalls the MDU pipeline for one clock in the M stage (high-performance MDU option without DSP configuration).
- A multiply operation stalls the MDU pipeline for 31 clocks in the M stage (area-efficient MDU option without DSP configuration).
- A multiply-accumulate operation stalls the MDU pipeline for 33 clocks in the M stage (area-efficient MDU option without DSP configuration).
- A divide operation stalls the MDU pipeline for a maximum of 38 clocks in the M stage. Early-in sign extension detection on the dividend will skip 7, 15, or 23 stall clocks (only the divider in the fast MDU option supports early-in detection).

A Stage: Align

During the Align stage:

- Load data is aligned to its word boundary.
- A multiply/divide operation updates the HI/LO registers (area-efficient MDU option).
- Multiply operation performs the carry-propagate-add. The actual register writeback is performed in the W stage (high-performance MDU option).
- A MUL operation makes the result available for writeback. The actual register writeback is performed in the W stage.
- EJTAG complex break conditions are evaluated.

W Stage: Writeback

During the Writeback stage:

- For register-to-register or load instructions, the instruction result is written back to the register file.

Virtualization Module

The Virtualization Module is supported in the M5100 core. Virtualization defines a set of extensions to the MIPS32

Architecture for efficient implementation of virtualized systems.

Virtualization is enabled by software—the key element is a control program known as a Virtual Machine Monitor (VMM) or hypervisor. The hypervisor is in full control of machine resources at all times.

When an operating system (OS) kernel runs within a virtual machine (VM), it becomes a guest of the hypervisor. All operations performed by a guest must be explicitly permitted by the hypervisor. To ensure that it remains in control, the hypervisor always runs at a higher level of privilege than a guest operating system kernel.

The hypervisor is responsible for managing access to sensitive resources, maintaining the expected behavior for each VM, and sharing resources between multiple VMs.

In a traditional operating system, the kernel (or supervisor) typically runs at a higher level of privilege than user applications. The kernel provides a protected virtual-memory environment for each user application, inter-process communications, IO device sharing and transparent context switching. The hypervisor performs the same basic functions in a virtualized system, except that the hypervisor's clients are full operating systems rather than user applications.

The virtual machine execution environment created and managed by the hypervisor consists of the full Instruction Set Architecture, including all Privileged Resource Architecture facilities, plus any device-specific or board-specific peripherals and associated registers. It appears to each guest operating system as if it is running on a real machine with full and exclusive control.

The Virtualization Module enables full virtualization, and is intended to allow VM scheduling to take place while meeting real-time requirements, and to minimize costs of context switching between VMs.

MIPS32® M5100 Core Required Logic Blocks

The required logic blocks of the M5100 core (Figure 1) are defined in the following subsections.

Execution Unit

The M5100 core execution unit implements a load/store architecture with single-cycle ALU operations (logical, shift, add, subtract) and an autonomous multiply/divide unit.

The execution unit includes:

- Arithmetic Logic Unit (ALU) for performing arithmetic and bitwise logical operations. Shared adder for arithmetic operations, load/store address calculation, and branch target calculation.
- Address unit for calculating the next PC and next fetch address selection muxes.
- Load Aligner.
- Shifter and Store Aligner.
- Branch condition comparator.
- Trap condition comparator.
- Bypass muxes to advance result between two adjacent instructions with data dependency.
- Leading Zero/One detect unit for implementing the CLZ and CLO instructions.
- Actual execution of the Atomic Instructions defined in the MCU ASE.
- A separate DSP ALU and Logic block for performing part of DSP Module instructions, such as arithmetic/shift/compare operations if the DSP function is configured.

General Purpose Registers

The M5100 core contains thirty-two 32-bit general-purpose registers used for integer operations and address calculation. Optionally, one, three, seven or fifteen additional register file shadow sets (each containing thirty-two registers) can be added to minimize context switching overhead during interrupt/exception processing. The register file consists of two read ports and one write port and is fully bypassed to minimize operation latency in the pipeline.

Multiply/Divide Unit (MDU)

The M5100 core includes a multiply/divide unit (MDU) that contains a separate, dedicated pipeline for integer multiply/divide operations, and DSP Module multiply instructions. This pipeline operates in parallel with the integer unit (IU) pipeline and does not stall when the IU pipeline stalls. This allows the long-running MDU operations to be partially masked by system stalls and/or other integer unit instructions.

The MIPS architecture defines that the result of a multiply or divide operation be placed in a pair (without DSP enabled) or one of 4 pairs (with DSP enabled) of *HI* and *LO* registers. Using the Move-From-HI (MFHI) and Move-From-LO (MFLO) instructions, these values can be transferred to the general-purpose register file.

There are three configuration options for the MDU: 1) a full 32x32 multiplier block; 2) a higher performance 32x16 multiplier block; 3) an area-efficient iterative multiplier

block. Option 2 and 3 are available if the DSP configuration option is disabled. If the DSP configuration option is enabled, option 1 is the default. The selection of the MDU style allows the implementor to determine the appropriate performance and area trade-off for the application.

MDU with 32x32 DSP Multiplier

With the DSP configuration option enabled, the MDU supports execution of one 16x16, 32x16, or 32x32 multiply or multiply-accumulate operation every clock cycle with the built in 32x32 multiplier array. The multiplier is shared with DSP Module operations.

The MDU also implements various shift instructions operating on the HI/LO register and multiply instructions as defined in the DSP Module. It supports all the data types required for this purpose and includes three extra HI/LO registers as defined by the Module.

Table 1 lists the latencies (throughput with data dependency) and repeat rates (throughput without data dependency) for the DSP multiply and dot-product operations. The approximate latencies and repeat rates are listed in terms of pipeline clocks. For a more detailed discussion of latencies and repeat rates, refer to the *MIPS32 M5100 Processor Core Software User's Manual*.

Table 1 DSP-related Latencies and Repeat Rates

Opcode	Latency	Repeat Rate
Multiply and dot-product without saturation after accumulation	5	1
Multiply and dot-product with saturation after accumulation	5	1
Multiply without accumulation	5	1

MDU with 32x16 High-Performance Multiplier

The high-performance MDU consists of a 32x16 Booth-recoded multiplier, a pair of result/accumulation registers (*HI* and *LO*), a divide state machine, and the necessary multiplexers and control logic. The first number ('32' of 32x16) represents the *rs* operand. The second number ('16' of 32x16) represents the *rt* operand. The M5100 core only checks the value of the *rt* operand to determine how many times the operation must pass through the multiplier. The

16x16 and 32x16 operations pass through the multiplier once. A 32x32 operation passes through the multiplier twice.

The MDU supports execution of one 16x16 or 32x16 multiply or multiply-accumulate operation every clock cycle; 32x32 multiply operations can be issued every other clock cycle. Appropriate interlocks are implemented to stall the issuance of back-to-back 32x32 multiply operations. The multiply operand size is automatically determined by logic built into the MDU.

Table 2, Table 3 and Table 4 list the repeat rate (how often the operation can be reissued when there is no data dependency) and latency (number of cycles until a result is available) for the multiply and divide instructions. The approximate latency and repeat rates are listed in terms of pipeline clocks. For a more detailed discussion of latencies and repeat rates, refer to Chapter 2 of the *MIPS32 M5100 Processor Core Family Software User's Manual*.

Table 2 High-Performance Integer Multiply/Divide Unit Latencies and Repeat Rates with DSP

Opcode	Operand Size (mul <i>rt</i>) (div <i>rs</i>)	Latency	Repeat Rate
MUL (GPR destination)	16 bits	5	1
	32 bits	5	1
MULT, MULTU, MADD, MADDU, MSUB, MSUBU (Hi/Lo destination)	16 bits	5	1
	32 bits	5	1
DIV / DIVU (Hi/Lo destination)	8 bits	12-14 / 12	12-14 / 12
	16 bits	20-22 / 20	20-22 / 20
	24 bits	28-30 / 30	28-30 / 30
	32 bits	35-37 / 35	35-37 / 35

Table 3 High-Performance Integer Multiply/Divide Unit Latencies and Repeat Rates without DSP

Opcode	Operand Size (mul <i>rt</i>) (div <i>rs</i>)	Latency	Repeat Rate
MUL (GPR destination)	16 bits	5	2
	32 bits	6	3

Table 3 High-Performance Integer Multiply/Divide Unit Latencies and Repeat Rates without DSP

Opcode	Operand Size (mul <i>rt</i>) (div <i>rs</i>)	Latency	Repeat Rate
MULT, MULTU, MADD, MADDU, MSUB, MSUBU (Hi/Lo destination)	16 bits	2	1
	32 bits	3	2
DIV / DIVU (Hi/Lo destination)	8 bits	11-12 / 11	11-12 / 11
	16 bits	19-20 / 19	19-20 / 19
	24 bits	27-28 / 27	27-28 / 27
	32 bits	34-35 / 34	34-35 / 34

MDU with Area-Efficient Option

With the area-efficient option, multiply and divide operations are implemented with a simple 1-bit-per-clock iterative algorithm. Any attempt to issue a subsequent MDU instruction while a multiply/divide is still active causes an MDU pipeline stall until the operation is completed.

Table 4 lists the latency (number of cycles until a result is available) for the M5100 core multiply and divide instructions. The latencies are listed in terms of pipeline clocks.

Table 4 Area-Efficient Integer Multiply/Divide Unit Operation Latencies without DSP

Opcode	Operand Size (mul <i>rt</i>) (div <i>rs</i>)	Latency	Repeat Rate
MUL (GPR destination)	any	35	32
MULT, MULTU, (Hi/Lo destination)	any	32	32
MADD, MADDU, MSUB, MSUBU (Hi/Lo destination)	any	34	34
DIV / DIVU (Hi/Lo destination)	any	33-34 / 33	33-34 / 33

Regardless of the multiplier array implementation, divide operations are implemented with a simple 1-bit-per-clock

iterative algorithm. An early-in detection checks the sign extension of the dividend (*rs*) operand. If *rs* is 8 bits wide, 23 iterations are skipped. For a 16-bit-wide *rs*, 15 iterations are skipped, and for a 24-bit-wide *rs*, 7 iterations are skipped. Any attempt to issue a subsequent MDU instruction while a divide is still active causes an IU pipeline stall until the divide operation has completed.

System Control Coprocessor (CP0)

In the MIPS architecture, CP0 is responsible for the virtual-to-physical address translation, the exception control system, the processor's diagnostics capability, the operating modes (kernel, user, and debug), and whether interrupts are enabled or disabled. Configuration information, such as presence of build-time options like microMIPS, CorExtend Module or Coprocessor 2 interface, is also available by accessing the CP0 registers.

Coprocessor 0 also contains the logic for identifying and managing exceptions. Exceptions can be caused by a variety of sources, including boundary cases in data, external events, or program errors.

Interrupt Handling

The M5100 core includes support for eight hardware interrupt pins, two software interrupts, and a timer interrupt. These interrupts can be used in any of three interrupt modes, as defined by Release 2 of the MIPS32 Architecture:

- Interrupt compatibility mode, which acts identically to that in an implementation of Release 1 of the Architecture.
- Vectored Interrupt (VI) mode, which adds the ability to prioritize and vector interrupts to a handler dedicated to that interrupt, and to assign a GPR shadow set for use during interrupt processing. The presence of this mode is denoted by the VInt bit in the *Config3* register. This mode is architecturally optional; but it is always present on the M5100 core, so the VInt bit will always read as a 1 for the M5100 core.
- External Interrupt Controller (EIC) mode, which redefines the way in which interrupts are handled to provide full support for an external interrupt controller handling prioritization and vectoring of interrupts. The presence of this mode denoted by the *VEIC* bit in the *Config3* register. Again, this mode is architecturally optional. On the M5100 core, the *VEIC* bit is set externally by the static input, *SI_EICPresent*, to allow system logic to indicate the presence of an external interrupt controller.

The reset state of the processor is interrupt compatibility mode, such that a processor supporting Release 2 of the Architecture, the M5100 core for example, is fully compatible with implementations of Release 1 of the Architecture.

VI or EIC interrupt modes can be combined with the optional shadow registers to specify which shadow set should be used on entry to a particular vector. The shadow registers further improve interrupt latency by avoiding the need to save context when invoking an interrupt handler.

In the M5100 core, interrupt latency is reduced by:

- Speculative interrupt vector prefetching during the pipeline flush.
- Interrupt Automated Prologue (IAP) in hardware: Shadow Register Sets remove the need to save GPRs, and IAP removes the need to save specific Control Registers when handling an interrupt.
- Interrupt Automated Epilogue (IAE) in hardware: Shadow Register Sets remove the need to restore GPRs, and IAE removes the need to restore specific Control Registers when returning from an interrupt.
- Allow interrupt chaining. When servicing an interrupt and interrupt chaining is enabled, there is no need to return from the current Interrupt Service Routine (ISR) if there is another valid interrupt pending to be serviced. The control of the processor can jump directly from the current ISR to the next ISR without IAE and IAP.

GPR Shadow Registers

The MIPS32 Architecture optionally removes the need to save and restore GPRs on entry to high-priority interrupts or exceptions, and to provide specified processor modes with the same capability. This is done by introducing multiple copies of the GPRs, called *shadow sets*, and allowing privileged software to associate a shadow set with entry to kernel mode via an interrupt vector or exception. The normal GPRs are logically considered shadow set zero.

The number of GPR shadow sets is a build-time option. The M5100 core allows 1 (the normal GPRs), 2, 4, 8, or 16 shadow sets. The highest number actually implemented is indicated by the $SRSCtl_{HSS}$ field. If this field is zero, only the normal GPRs are implemented.

Shadow sets are new copies of the GPRs that can be substituted for the normal GPRs on entry to kernel mode via an interrupt or exception. Once a shadow set is bound to a kernel-mode entry condition, references to GPRs operate exactly as one would expect, but they are redirected to registers that are dedicated to that condition. Privileged software may need to reference all GPRs in the register file, even specific shadow registers that are not visible in the current mode, and the RDPGPR and WRPGPR instructions are used for this purpose. The CSS field of the $SRSCtl$ register provides the number of the current shadow register set, and the PSS field of the $SRSCtl$ register provides the number of the previous shadow register set that was current before the last exception or interrupt occurred.

If the processor is operating in VI interrupt mode, binding of a vectored interrupt to a shadow set is done by writing to the $SRSM_{ap}$ register. If the processor is operating in EIC interrupt mode, the binding of the interrupt to a specific shadow set is provided by the external interrupt controller and is configured in an implementation-dependent way. Binding of an exception or non-vectored interrupt to a shadow set is done by writing to the ESS field of the $SRSCtl$ register. When an exception or interrupt occurs, the value of $SRSCtl_{CSS}$ is copied to $SRSCtl_{PSS}$, and $SRSCtl_{CSS}$ is set to the value taken from the appropriate source. On an ERET, the value of $SRSCtl_{PSS}$ is copied back into $SRSCtl_{CSS}$ to restore the shadow set of the mode to which control returns.

Modes of Operation

The M5100 core implements the Virtualization Module by supporting five modes of operation:

- *Guest-user mode* is most often used for applications programs.
- *Guest-kernel mode* is typically used for handling exceptions and operating-system kernel functions, including CP0 management and I/O device accesses.
- *Root-user mode* is used to run hypervisor (Virtual Machine Monitor (VMM)) user software.
- *Root-kernel mode* is used to run hypervisor (Virtual Machine Monitor (VMM)) kernel software.
- *Debug mode* is used during system bring-up and software development. Refer to the EJTAG section for more information on debug mode.

Figure 3 shows the virtual address map of the MIPS Architecture.

Figure 3 M5100 Core Virtual Address Map

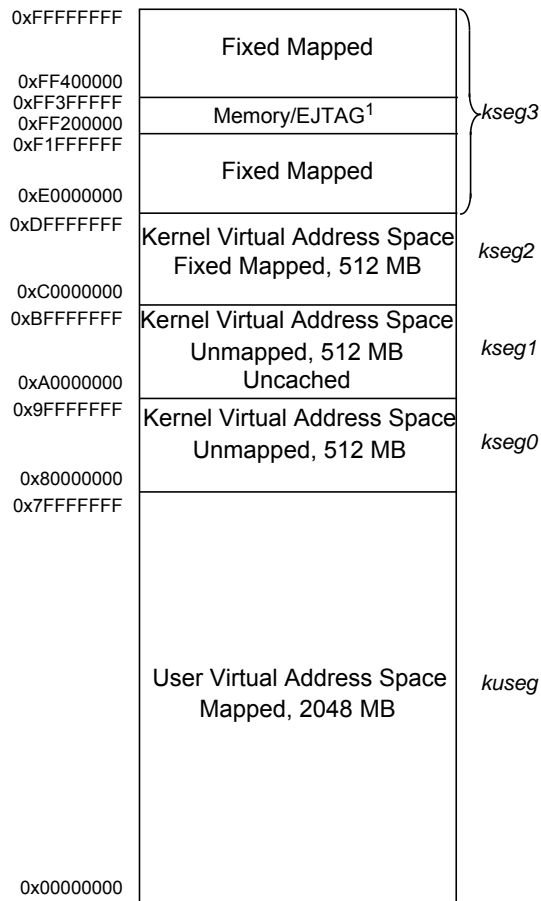

1. This space is mapped to memory in user or kernel mode, and by the EJTAG module in debug mode.

Memory Management Unit (MMU) in Guest Modes

The M5100 core contains a simple Fixed Mapping Translation (FMT) MMU that interfaces between the execution unit and the SRAM controller.

Fixed Mapping Translation (FMT)

A FMT is smaller and simpler than the full Translation Lookaside Buffer (TLB) style MMU found in other MIPS cores. Like a TLB, the FMT performs virtual-to-physical address translation and provides attributes for the different segments. Those segments that are unmapped in a TLB implementation (kseg0 and kseg1) are translated identically by the FMT.

Memory Management Unit (MMU) in Root Modes

The M5100 core provides a Root Protection Unit (RPU) MMU for guest virtual-address protection.

Root Protection Unit (RPU)

A RPU-based MMU is similar to an RTLB in that it consists of 8, 16, or 32 dual-entry fully associative look-aside buffer, but the segments that are unmapped in a TLB implementation (kseg0 and kseg1) are translated identically by the RPU.

The RPU allows guest pages to be protected by a read-inhibit, execute-inhibit, and write-protection attribute.

When an instruction address is calculated, the virtual address is first compared to the contents of the 4-entry IFMT . If the address is not found, the virtual address is fixed mapped and validated by the RPU. If the address is not found in the RPU, a refill exception is taken.

When a data address is calculated, the virtual address is compared to the 4-entry DFMT . If the address is not found, the virtual address is fixed mapped and validated by the RPU. If the address is not found in the RPU, a refill exception is taken.

Figure 4 shows how the FMT is implemented in the M5100 core.

Figure 4 Address Translation During SRAM Access with FMT Implementation

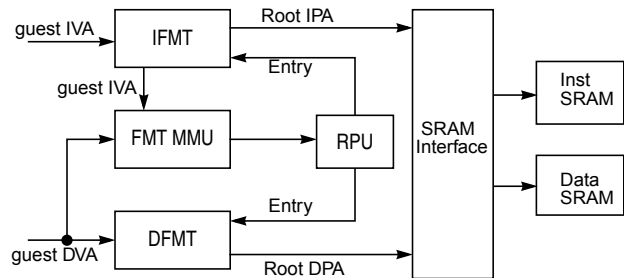

SRAM Interface Controller

Instead of caches, the M5100 core contains an interface to SRAM-style memories that can be tightly coupled to the core. This permits deterministic response time with less area than is typically required for caches. The SRAM interface includes separate uni-directional 32-bit buses for address, read data, and write data.

Dual or Unified Interfaces

The SRAM interface includes a build-time option to select either dual or unified instruction and data interfaces.

The dual interface enables independent connection to instruction and data devices. It generally yields the highest

performance, because the pipeline can generate simultaneous I and D requests, which are then serviced in parallel.

For simpler or cost-sensitive systems, it is also possible to combine the I and D interfaces into a common interface that services both types of requests. If I and D requests occur simultaneously, priority is given to the D side.

Back-stalling

Typically, read and write transactions will complete in a single cycle. However, if multi-cycle latency is desired, the interface can be stalled to allow connection to slower devices.

Redirection

When the dual I/D interface is present, a mechanism exists to divert D-side references to the I-side, if desired. The mechanism can be explicitly invoked for any other D-side references, as well. When the *DS_Redir* signal is asserted, a D-side request is diverted to the I-side interface in the following cycle, and the D-side will be stalled until the transaction is completed.

Transaction Abort

The core may request a transaction (fetch/load/store/sync) to be aborted. This is particularly useful in case of interrupts. Because the core does not know whether transactions are re-startable, it cannot arbitrarily interrupt a request which has been initiated on the SRAM interface. However, cycles spent waiting for a multi-cycle transaction to complete can directly impact interrupt latency. In order to minimize this effect, the interface supports an abort mechanism. The core requests an abort whenever an interrupt is detected and a transaction is pending (abort of an instruction fetch may also be requested in other cases). The external system logic can choose to acknowledge or to ignore the abort request.

Connecting to Narrower Devices

The instruction and data read buses are always 32 bits in width. To facilitate connection to narrower memories, the SRAM interface protocol includes input byte-enables that can be used by system logic to signal validity as partial read data becomes available. The input byte-enables conditionally register the incoming read data bytes within the core, and thus eliminate the need for external registers to gather the entire 32 bits of data. External muxes are required to redirect the narrower data to the appropriate byte lanes.

Lock Mechanism

The SRAM interface includes a protocol to identify a locked sequence, and is used in conjunction with the LL/SC atomic read-modify-write semaphore instructions.

Sync Mechanism

The interface includes a protocol that externalizes the execution of the SYNC instruction. External logic might choose to use this information to enforce memory ordering between various elements in the system.

External Call Indication

The instruction fetch interface contains signals that indicate that the core is fetching the target of a subroutine call-type instruction such as JAL or BAL. At some point after a call, there will typically be a return to the original code sequence. If a system prefetches instructions, it can make use of this information to save instructions that were prefetched and are likely to be executed after the return.

Hardware Reset

The M5100 core has two types of reset input signals: *SI_Reset* and *SI_ColdReset*. Functionally, these two signals are ORed together within the core and then used to initialize critical hardware state.

Both reset signals can be asserted either synchronously or asynchronously to the core clock, *SI_ClkIn*, and will trigger a Reset exception. The reset signals are active high and must be asserted for a minimum of 5 *SI_ClkIn* cycles. The falling edge triggers the Reset exception.

The primary difference between the two reset signals is that *SI_Reset* sets a bit in the *Status* register; this bit could be used by software to distinguish between the two reset signals, if desired. The reset behavior is summarized in [Table 5](#).

Table 5 Reset Types

SI_Reset	SI_ColdReset	Action
0	0	Normal operation, no reset.
1	0	Reset exception; sets <i>Status_{SR}</i> bit.
X	1	Reset exception.

One (or both) of the reset signals must be asserted at power-on or whenever hardware initialization of the core is desired. A power-on reset typically occurs when the machine is first

turned on. A hard reset usually occurs when the machine is already on and the system is rebooted.

In debug mode, EJTAG can request that a soft reset (via the *SI_Reset* pin) be masked. It is system-dependent whether this functionality is supported. In normal mode, the *SI_Reset* pin cannot be masked. The *SI_ColdReset* pin is never masked.

Power Management

The M5100 core offers a number of power management features, including low-power design, active power management, and power-down modes of operation. The core is a static design that supports slowing or halting the clocks, which reduces system power consumption during idle periods.

The M5100 core provides two mechanisms for system-level low-power support:

- Register-controlled power management
- Instruction-controlled power management

Register-Controlled Power Management

The *RP* bit in the CP0 *Status* register provides a software mechanism for placing the system into a low-power state. The state of the *RP* bit is available externally via the *SI_RP* signal. The external agent then decides whether to place the device in a low-power mode, such as reducing the system clock frequency.

Three additional bits, *Status_EXL*, *Status_ERL*, and *Debug_DM* support the power management function by allowing the user to change the power state if an exception or error occurs while the M5100 core is in a low-power state. Depending on what type of exception is taken, one of these three bits will be asserted and reflected on the *SI_EXL*, *SI_ERL*, or *EJ_DebugM* outputs. The external agent can look at these signals and determine whether to leave the low-power state to service the exception.

The following four power-down signals are part of the system interface and change state as the corresponding bits in the CP0 registers are set or cleared:

- The *SI_RP* signal represents the state of the *RP* bit (27) in the CP0 *Status* register.
- The *SI_EXL* signal represents the state of the *EXL* bit (1) in the CP0 *Status* register.
- The *SI_ERL* signal represents the state of the *ERL* bit (2) in the CP0 *Status* register.
- The *EJ_DebugM* signal represents the state of the *DM* bit (30) in the CP0 *Debug* register.

Instruction-Controlled Power Management

The second mechanism for invoking power-down mode is by executing the WAIT instruction. When the WAIT instruction is executed, the internal clock is suspended; however, the internal timer and some of the input pins (*SI_Int[5:0]*, *SI_NMI*, *SI_Reset*, and *SI_ColdReset*) continue to run. Once the CPU is in instruction-controlled power management mode, any interrupt, NMI, or reset condition causes the CPU to exit this mode and resume normal operation.

The M5100 core asserts the *SI_Sleep* signal, which is part of the system interface bus, whenever the WAIT instruction is executed. The assertion of *SI_Sleep* indicates that the clock has stopped and the M5100 core is waiting for an interrupt.

Local clock gating

The majority of the power consumed by the M5100 core is in the clock tree and clocking registers. The core has support for extensive use of local gated-clocks. Power-conscious implementors can use these gated clocks to significantly reduce power consumption within the core.

MIPS32® M5100 Core Optional or Configurable Logic Blocks

The M5100 core contains several optional or configurable logic blocks, shown as shaded in the block diagram in [Figure 1](#).

Reference Design

The M5100 core contains a reference design that shows a typical usage of the core with:

- Dual I-SRAM and D-SRAM interface with fast memories (i.e., SRAM) for instruction and data storage.
- Optimized interface for slow memory (i.e., Flash memory) access by having a prefetch buffer and a wider Data Read bus (i.e., *IS_RData[127:0]*) to speed up I-Fetch performance.
- AHB-lite bus interface to the system bus if the memory accesses are outside the memory map for the SRAM and Flash regions. AHB-Lite is a subset of the AHB bus protocol that supports a single bus master. The interface shares the same 32-bit Read and Write address bus and has two unidirectional 32-bit buses for Read and Write data.

The reference design is optional and can be modified by the user to better fit the SOC design requirement.

Figure 5 Reference Design Block Diagram.

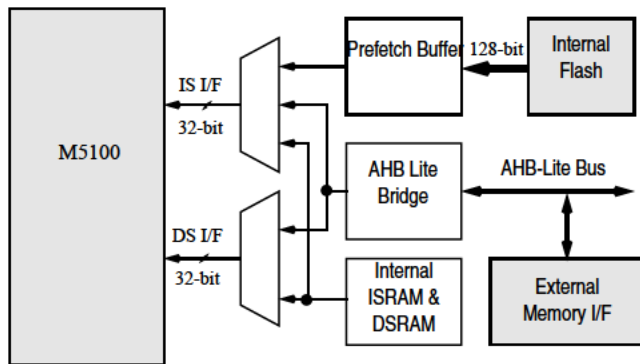

microMIPS™ ISA

The M5100 core supports the microMIPS ISA, which contains all MIPS32 ISA instructions (except for branch-likely instructions) in a new 32-bit encoding scheme, with some of the commonly used instructions also available in 16-bit encoded format. This ISA improves code density through the additional 16-bit instructions while maintaining a performance similar to MIPS32 mode. In microMIPS mode, 16-bit or 32-bit instructions will be fetched and recoded to legacy MIPS32 instruction opcodes in the pipeline's I stage, so that the M5100 core can have the same microAptiv™ UC microarchitecture. Because the microMIPS instruction stream can be intermixed with 16-bit halfword or 32-bit word size instructions on halfword or word boundaries, additional logic is in place to address the word misalignment issues, thus minimizing performance loss.

DSP Module

The M5100 core implements an optional DSP Module to benefit a wide range of DSP, Media, and DSP-like algorithms. The DSP module is highly integrated with the Execution Unit and the MDU in order to share common logic and to include support for operations on fractional data types, saturating arithmetic, and register SIMD operations. Fractional data types Q15 and Q31 are supported. Register SIMD operations can perform up to four simultaneous add, subtract, or shift operations and two simultaneous multiply operations.

In addition, the DSP Module includes some key features that efficiently address specific problems often encountered in DSP applications. These include, for example, support for complex multiply, variable-bit insert and extract, and implementation and use of virtual circular buffers. The extension also makes available three additional sets of HI-LO accumulators to better facilitate common accumulate functions such as filter operation and convolutions.

Floating Point Unit (FPU)

The M5100 core Floating Point Unit (FPU) implements the MIPS Instruction Set Architecture for floating-point computation. The implementation supports the ANSI/IEEE Standard 754 (IEEE Standard for Binary Floating-Point Arithmetic) for single and double precision data formats. The FPU can be programmed to have thirty-two 32-bit or 64-bit floating-point registers used for floating point operations.

The performance is optimized for single precision formats. Most instructions have one FPU cycle throughput and four FPU cycle latency. The FPU implements the multiply-add (MADD) and multiply-sub (MSUB) instructions with intermediate rounding after the multiply function. The result is guaranteed to be the same as executing a MUL and an ADD instruction separately, but the instruction latency, instruction fetch, dispatch bandwidth, and the total number of register accesses are improved.

IEEE denormalized input operands and results are supported by hardware for some instructions. IEEE denormalized results are not supported by hardware in general, but a fast flush-to-zero mode is provided to optimize performance. The fast flush-to-zero mode is enabled through the *FCCR* register, and use of this mode is recommended for best performance when denormalized results are generated.

The FPU has a separate pipeline for floating point instruction execution. This pipeline operates in parallel with the integer core pipeline and does not stall when the integer pipeline stalls. This allows long-running FPU operations, such as divide or square root, to be partially masked by system stalls and/or other integer unit instructions. Arithmetic instructions are always dispatched and completed in order, but loads and stores can complete out of order. The exception model is 'precise' at all times.

FPU Pipeline

The FPU implements a high-performance 7-stage pipeline:

- Decode, register read and unpack (FR stage)
- Multiply tree - double pumped for double (M1 stage)
- Multiply complete (M2 stage)
- Addition first step (A1 stage)
- Addition second and final step (A2 stage)
- Packing to IEEE format (FP stage)
- Register writeback (FW stage)

The FPU implements a bypass mechanism that allows the result of an operation to be forwarded directly to the instruction that needs it without having to write the result to the FPU register and then read it back.

Figure 6 shows the FPU pipeline.

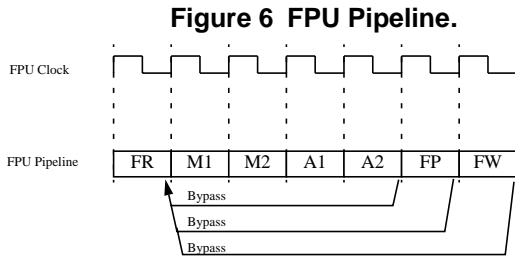

FPU Instruction Latencies and Repeat Rates

Table 6 contains the floating point instruction latencies and repeat rates for the M5100 core. In this table, ‘Latency’ refers to the number of FPU cycles necessary for the first instruction to produce the result needed by the second instruction. The ‘Repeat Rate’ refers to the maximum rate at which an instruction can be executed per FPU cycle.

Table 6 M5100 Core FPU Latency and Repeat Rate

Opcode*	Latency (FPU cycles)	Repeat Rate (FPU cycles)
ABS.[S,D], NEG.[S,D], ADD.[S,D], SUB.[S,D], C.cond.[S,D], MUL.S	4	1
MADD.S, MSUB.S, NMADD.S, NMSUB.S, CABS.cond.[S,D]	4	1
CVT.D.S, CVT.PS.PW, CVT.[S,D].[W,L]	4	1
CVT.S.D, CVT.[W,L].[S,D], CEIL.[W,L].[S,D], FLOOR.[W,L].[S,D], ROUND.[W,L].[S,D], TRUNC.[W,L].[S,D]	4	1
MOV.[S,D], MOVF.[S,D], MOVN.[S,D], MOVT.[S,D], MOVZ.[S,D]	4	1
MUL.D	5	2
* Format: S = Single, D = Double, W = Word, L = Long-word		

Table 6 M5100 Core FPU Latency and Repeat Rate (Continued)

Opcode*	Latency (FPU cycles)	Repeat Rate (FPU cycles)
MADD.D, MSUB.D, NMADD.D, NMSUB.D	5	2
RECIP.S	13	10
RECIP.D	26	21
RSQRT.S	17	14
RSQRT.D	36	31
DIV.S, SQRT.S	17	14
DIV.D, SQRT.D	32	29
MTC1, DMTC1, LWC1, LDC1, LDXC1, LUXC1, LWXC1	4	1
MFC1, DMFC1, SWC1, SDC1, SDXC1, SUXC1, SWXC1	1	1
* Format: S = Single, D = Double, W = Word, L = Long-word		

Coprocessor 2 Interface

The M5100 core can be configured to have an interface for an on-chip coprocessor. This coprocessor can be tightly coupled to the processor core, allowing high-performance solutions integrating a graphics accelerator or DSP, for example.

The coprocessor interface is extensible and standardized on MIPS cores, allowing for design reuse. The M5100 core supports a subset of the full coprocessor interface standard: 32b data transfer, no Coprocessor 1 support, single issue in-order data transfer to coprocessor, one out-of-order data transfer from coprocessor.

The coprocessor interface is designed to ease integration with customer IP. The interface allows high-performance communication between the core and coprocessor. There are no late or critical signals on the interface.

CorExtend® User-defined Instruction Extensions

An optional CorExtend User-defined Instruction (UDI) block enables the implementation of a small number of application-specific instructions that are tightly coupled to the core’s

execution unit. The interface to the UDI block is external to the M5100 core.

Such instructions may operate on a general-purpose register, immediate data specified by the instruction word, or local state stored within the UDI block. The destination may be a general-purpose register or local UDI state. The operation may complete in one cycle or multiple cycles, if desired.

Anti-Tamper Security Features

The core provides security features that counter side-channel attacks attempting to reveal the code or data running on the processor.

Random slips can be generated in order to disguise the timing and power profile of an algorithm executing on the processor. This reduces the core's vulnerability to side channel attacks. Power management techniques are used to ensure that the power profile of a random slip is indistinguishable from the power profile of the executing instructions.

The core contains a general-purpose pseudo generator for use by software. The generator may optionally be designed by the implementor of the core, thus allowing the quality of the pseudo random number sequences to be suited for any needs.

EJTAG Debug Support

The M5100 core provides for an optional Enhanced JTAG (EJTAG) interface for use in the software debug of application and kernel code. In addition to standard user mode and kernel modes of operation, the M5100 core provides a Debug mode that is entered after a debug exception (derived from a hardware breakpoint, single-step exception, etc.) is taken and continues until a debug exception return (DERET) instruction is executed. During this time, the processor executes the debug exception handler routine.

The EJTAG interface operates through the Test Access Port (TAP), a serial communication port used for transferring test data in and out of the M5100 core. In addition to the standard JTAG instructions, special instructions defined in the EJTAG specification specify which registers are selected and how they are used.

Debug Registers

Four debug registers (*DEBUG*, *DEBUG2*, *DEPC*, and *DESAVE*) have been added to the MIPS Coprocessor 0 (CP0) register set. The *DEBUG* and *DEBUG2* registers show the cause of the debug exception and are used for setting up single-step operations. The *DEPC* (Debug Exception Program Counter) register holds the address on which the debug exception was taken, which is used to resume program execution after the

debug operation finishes. Finally, the *DESAVE* (Debug Exception Save) register enables the saving of general-purpose registers used during execution of the debug exception handler.

To exit debug mode, a Debug Exception Return (DERET) instruction is executed. When this instruction is executed, the system exits debug mode, allowing normal execution of application and system code to resume.

EJTAG Hardware Breakpoints

There are several types of *simple* hardware breakpoints defined in the EJTAG specification. These stop the normal operation of the CPU and force the system into debug mode. There are two types of simple hardware breakpoints implemented in the M5100 core: Instruction breakpoints and Data breakpoints. Additionally, *complex* hardware breakpoints can be included, which allow detection of more intricate sequences of events.

The M5100 core can be configured with the following breakpoint options:

- No data or instruction, or complex breakpoints
- One data and two instruction breakpoints, without complex breakpoints
- Two data and four instruction breakpoints, without complex breakpoints
- Two data and six instruction breakpoints, with or without complex breakpoints
- Four data and eight instruction breakpoints, with or without complex breakpoints

Instruction breakpoints occur on instruction execution operations, and the breakpoint is set on the virtual address. A mask can be applied to the virtual address to set breakpoints on a binary range of instructions.

Data breakpoints occur on load/store transactions, and the breakpoint is set on a virtual address value, with the same single address or binary address range as the Instruction breakpoint. Data breakpoints can be set on a load, a store, or both. Data breakpoints can also be set to match on the operand value of the load/store operation, with byte-granularity masking. Finally, masks can be applied to both the virtual address and the load/store value.

In addition, the M5100 core has a configurable feature to support data and instruction address-range triggered breakpoints, where a breakpoint can occur when a virtual address is either within or outside a pair of 32-bit addresses. Unlike the traditional address-mask control, address-range

triggering is not restricted to a power-of-two binary boundary.

Complex breakpoints utilize the simple instruction and data breakpoints and break when combinations of events are seen. Complex break features include:

- **Pass Counters** - Each time a matching condition is seen, a counter is decremented. The break or trigger will only be enabled when the counter has counted down to 0.
- **Tuples** - A tuple is the pairing of an instruction and a data breakpoint. The tuple will match if both the virtual address of the load or store instruction matches the instruction breakpoint, and the data breakpoint of the resulting load or store address and optional data value matches.
- **Priming** - This allows a breakpoint to be enabled only after other break conditions have been met. Also called sequential or armed triggering.
- **Qualified** - This feature uses a data breakpoint to qualify when an instruction breakpoint can be taken. Once a load matches the data address and the data value, the instruction break will be enabled. If a load matches the address, but has mis-matching data, the instruction break will be disabled.

Performance Counters

Performance counters are used to accumulate occurrences of internal predefined events/cycles/conditions for program analysis, debug, or profiling. A few examples of event types are clock cycles, instructions executed, specific instruction types executed, loads, stores, exceptions, and cycles while the CPU is stalled. There are two, 32-bit counters. Each can count one of the 64 internal predefined events selected by a corresponding control register. A counter overflow can be programmed to generate an interrupt, where the interrupt handler software can maintain larger total counts.

PC/Address Sampling

This sampling function is used for program profiling and hot-spots analysis. Instruction PC and/or Load/Store addresses can be sampled periodically. The result is scanned out through the EJTAG port. The Debug Control Register (*DCR*) is used to specify the sample period and the sample trigger.

Fast Debug Channel (FDC)

The M5100 core includes optional FDC as a mechanism for high bandwidth data transfer between a debug host/probe and a target. FDC provides a FIFO buffering scheme to transfer

data serially, with low CPU overhead and minimized waiting time. The data transfer occurs in the background, and the target CPU can either choose to check the status of the transfer periodically, or it can choose to be interrupted at the end of the transfer.

Figure 7 FDC Overview

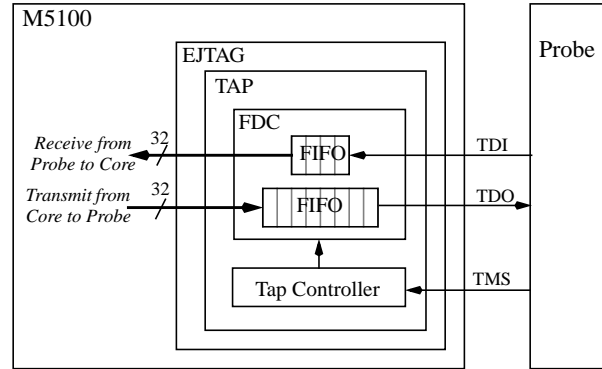

iFlowtrace™

The M5100 core has an option for a simple trace mechanism called iFlowtrace. This mechanism only traces the instruction PC, not data addresses or values. This simplification allows the trace block to be smaller and the trace compression to be more efficient. iFlowtrace memory can be configured as off-chip, on-chip, or both.

iFlowtrace also offers special-event trace modes when normal tracing is disabled, namely:

- **Function Call/Return and Exception Tracing mode** to trace the PC value of function calls and returns and/or exceptions and returns.
- **Breakpoint Match mode** traces the breakpoint ID of a matching breakpoint and, for data breakpoints, the PC value of the instruction that caused it.
- **Filtered Data Tracing mode** traces the ID of a matching data breakpoint, the load or store data value, access type and memory access size, and the low-order address bits of the memory access, which is useful when the data breakpoint is set up to match a binary range of addresses.
- **User Trace Messages.** The user can instrument their code to add their own 32-bit value messages into the trace by writing to the Cop0 UTM register.
- **Delta Cycle mode** works in combination with the above trace modes to provide a timestamp between stored events. It reports the number of cycles that have elapsed since the last message was generated and put into the trace.

cJTAG Support

The M5100 core provides an external conversion block which converts the existing EJTAG (IEEE 1149.1) 4-wire interface at the M5100 core to a cJTAG (IEEE 1149.7) 2-wire interface. cJTAG reduces the number of wires from 4 to 2 and enables the support of Star-2 scan topology in the system debug environment.

Figure 8 cJTAG Support

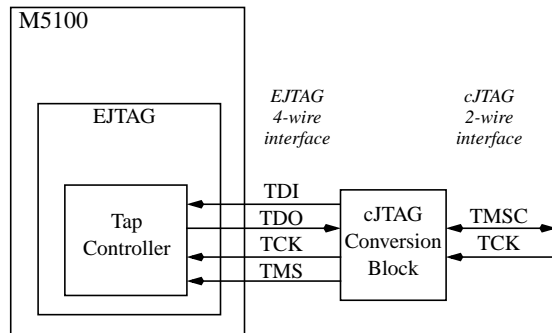

SecureDebug

SecureDebug improves security by disabling untrusted EJTAG debug access. An input signal is used to disable debug features, such as Probe Trap, Debug Interrupt Exception (EjtagBrk and DINT), EJTAGBOOT instruction, and PC Sampling.

Testability

Testability for production testing of the core is supported through the use of internal scan and memory BIST.

Internal Scan

Full mux-based scan for maximum test coverage is supported, with a configurable number of scan chains. ATPG test coverage can exceed 99%, depending on standard cell libraries and configuration options.

Memory BIST

Memory BIST for the on-chip trace memory is optional.

Memory BIST can be inserted with a CAD tool or other user-specified method. Wrapper modules and special side-band signal buses of configurable width are provided within the core to facilitate this approach.

Build-Time Configuration Options

The M5100 core allows a number of features to be customized based on the intended application. [Table 7](#) summarizes the key configuration options that can be selected when the core is synthesized and implemented.

For a core that has already been built, software can determine the value of many of these options by checking an appropriate register field. Refer to the *MIPS32® M5100 Processor Core Family Software User's Manual* for a more complete description of these fields. The value of some options that do not have a functional effect on the core are not visible to software.

Table 7 Build-time Configuration Options

Option	Choices	Software Visibility
Integer register file sets	1, 2, 4, 8 or 16	<i>SRSCtl</i> _{HSS}
Integer register file implementation style	Flops or generator	N/A
Virtualization number of guests	1, 2, 3, 4, 5, 6, 7	N/A
ISA support	MIPS32 only, or microMIPS only, or MIPS32 and microMIPS present	<i>Config3</i> _{ISA}
DSP Module	Present or not	<i>Config3</i> _{DSPP} <i>Config3</i> _{DSP2P}
Multiply/divide implementation style	High performance or min area (if DSP is not present)	<i>Config</i> _{MDU}
Floating-point Unit	Present or not	<i>Config1</i> _{FP}

* These bits indicate the presence of an external block. Bits will not be set if interface is present, but block is not.

Table 7 Build-time Configuration Options (Continued)

Option	Choices	Software Visibility
Adder implementation style	Structured or Simple	N/A
EJTAG TAP controller	Present or not	N/A
EJTAG TAP Fast Debug Channel (FDC)	Present or not (even when TAP is present)	DCR_{FDCI}
EJTAG TAP FDC FIFO size	Two TX/two RX, or eight TX/four RX 32-bit registers	$FDCFG$
Instruction/data hardware breakpoints	0/0, 2/1, 4/2, 6/2, or 8/4	$DCR_{InstBrk}$, IBS_{BCN} $DCR_{DataBrk}$, DBS_{BCN}
Hardware breakpoint trigger by	Address match, or Address match and address range	$IBCn_{hwart}$, $DBCn_{hwart}$
Complex breakpoints	0/0, 6/2, or 8/4	DCR_{CBT}
Performance Counters	Present or not	$Config1_{PC}$
iFlowtrace hardware	Present or not	$Config3_{ITL}$
iFlowtrace memory location	On-core or off-chip	$IFCTL_{ofc}$
iFlowtrace on-chip memory size	256B - 8MB	N/A
CorExtend interface	Present or not	$ConfigUDI^*$
Coprocessor2 interface	Present or not	$Config1_{C2}^*$
SRAM interface style	Separate instruction/data or unified	$Config_{DS}$
SRAM Parity	Present or not	$ErrCtl_{PE}$
Interrupt synchronizers	Present or not	N/A
Interrupt Vector Offset	Compute from Vector Input or Immediate Offset	N/A
Clock gating	Top-level, integer register file array, fine-grain, or none	N/A
PC Sampling	Present or not	Debug Control Register
Data Address Sampling	Present or not	Debug Control Register
PRID	User defined Processor Identification	$PRID_{CompanyOpt}$

* These bits indicate the presence of an external block. Bits will not be set if interface is present, but block is not.

Revision History

Revision	Date	Description
01.00	December 31, 2013	• Initial 1_0_0 release.

